

Data sheet

Seated valves (PN 16)

VRG 2 – 2-way valve, external thread

VRG 3 – 3-way valve, external thread

Description



VRG valves provide a quality, cost effective solution for most water and chilled applications.

The valves are designed to be combined with AMV(E) 335, AMV(E) 435 or AMV(E) 438 SU actuators.

Combinations with other actuators could be seen under Accessories.

Main data:

- DN 15-50
- k_{vs} 0.63-40 m³/h
- PN 16
- Temperature:
 - Circulation water / glycolic water up to 50 %: 2 (-10*) ... 130 °C
 - * At temperatures from -10 °C up to +2 °C use stem heater
- Connections:
 - External thread
- Compliance with Pressure Equipment Directive 97/23/EC

Ordering

Example:
3-way valve, DN 15, k_{vs} 1.6, PN 16,
 t_{max} 130 °C, ext. thread

- 1x VRG 3 DN 15 valve
Code No.: **065Z0113**

Option:
- 1x Tailpieces
Code No.: **065Z0291**

2 & 3-way valves VRG (external thread)

DN	k_{vs} (m ³ /h)	Code No.	
		VRG 2	VRG 3
15	0.63	065Z0131	065Z0111
	1.0	065Z0132	065Z0112
	1.6	065Z0133	065Z0113
	2.5	065Z0134	065Z0114
	4.0	065Z0135	065Z0115
20	6.3	065Z0136	065Z0116
25	10	065Z0137	065Z0117
32	16	065Z0138	065Z0118
40	25	065Z0139	065Z0119
50	40	065Z0140	065Z0120

Accessories-Tailpieces

Type	DN	Code No.
Tailpieces ¹⁾	Rp ½	15 065Z0291
	Rp ¾	20 065Z0292
	Rp 1	25 065Z0293
	Rp 1¼	32 065Z0294
	Rp 1½	40 065Z0295
	Rp 2	50 065Z0296
Adapter DN 15-50 / AMV(E)15,25,35		065Z0311

¹⁾ 1 tailpiece internal thread for VRG ext. thread (Ms - CuZn39Pb3)

Accessories - Adapter

Actuators	max. Δp (bar)	Code No.
AMV(E) 15, 25, 35, 323, 423, 523	4.0	065Z0311

Service kits

Type	DN	Code No.
Stuffing box	15	065Z0321
	20	065Z0322
	25	065Z0323
	32	065Z0324
	40/50	065Z0325

Accessories - Stem heater

Actuators	Power supply	Code No.
AMV(E) 335, 435	24 V	065Z0315
AMV(E) 438 SU		065B2171

Technical data

Nominal diameter	DN	15					20	25	32	40	50
k_{VS} value	m ³ /h	0.63	1.0	1.6	2.5	4.0	6.3	10	16	25	40
Stroke	mm	10					15				
Control range		30:1	50:1			100:1					
Control characteristic		LOG: port A-AB; LIN: port B-AB									
Cavitation factor z		≥ 0.4									
Leakage acc. to standard IEC 534		A - AB ≤ 0.05 % of k_{VS}									
		B - AB ≤ 1.0 % of k_{VS}									
Nominal pressure	PN	16									
Max. closing pressure	bar	4									
Medium		Circulation water / glycolic water up to 50 %									
Medium pH		Min. 7, Max. 10									
Medium temperature	°C	2 (-10 ¹⁾) ... 130									
Connections		ext. thread									
Materials											
Valve body		Grey cast iron EN-GJL-250 (GG-25)									
Valve stem		Stainless steel									
Valve cone		Brass									
Stuffing box sealing		EPDM									

¹⁾ At temperatures from -10 up to +2 °C use stem heater

Pressure temperature diagram

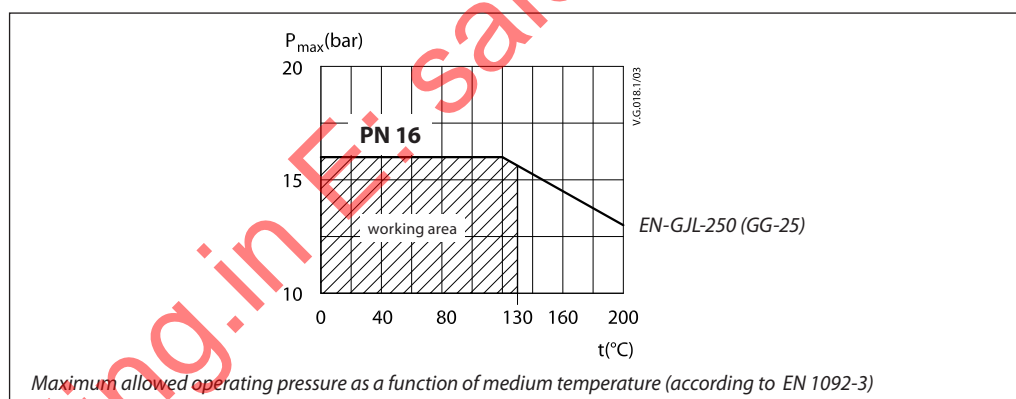

Valve characteristics

Valve characteristics log (2-way)

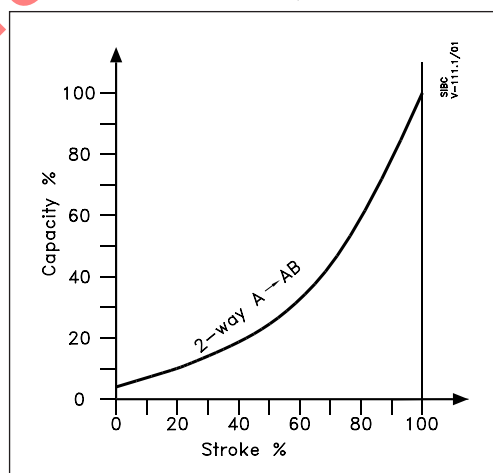

Valve characteristics log/lin (3-way)

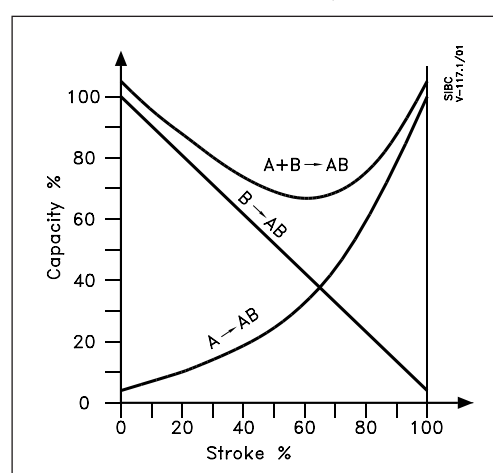

Installation

Valve mounting

Before valve mounting the pipes have to be cleaned and free from abrasion. Valve must be mounted according to flow direction as indicated on valve body. Mechanical loads of the valve body caused by the pipes are not allowed. Valve should be free of vibrations as well.

Installation of the valve with the actuator is allowed in horizontal position or upwards. Installation downwards is not allowed.

Application schemes for 3-way mixing valves

3-way valve is mixing valve meaning that A and B ports are inlet ports, and AB port is outlet port (fig. 1). In case valve should be used as diverting valve (which is in general not allowed) it is a solution to install valve in return pipe (fig. 2).

Remark:

3-way valve can be used as diverting valve (AB is inlet port, A and B are outlet ports) but only up to differential pressure over the valve equal to 1/10 of max. closing pressure stated in Technical data section.

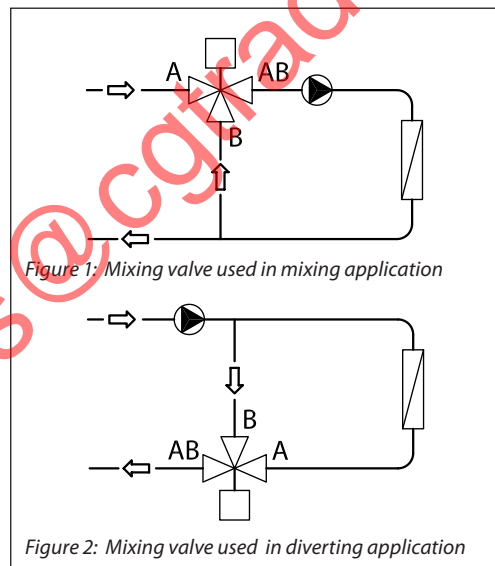
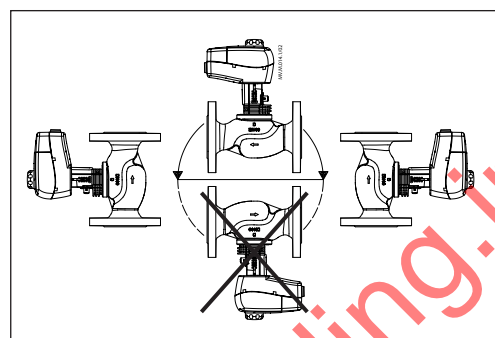

Disposal

The valve must be dismantled and the elements sorted into various material groups before disposal.

www.cgtrading.in E: sales@cgtrading.in

Sizing

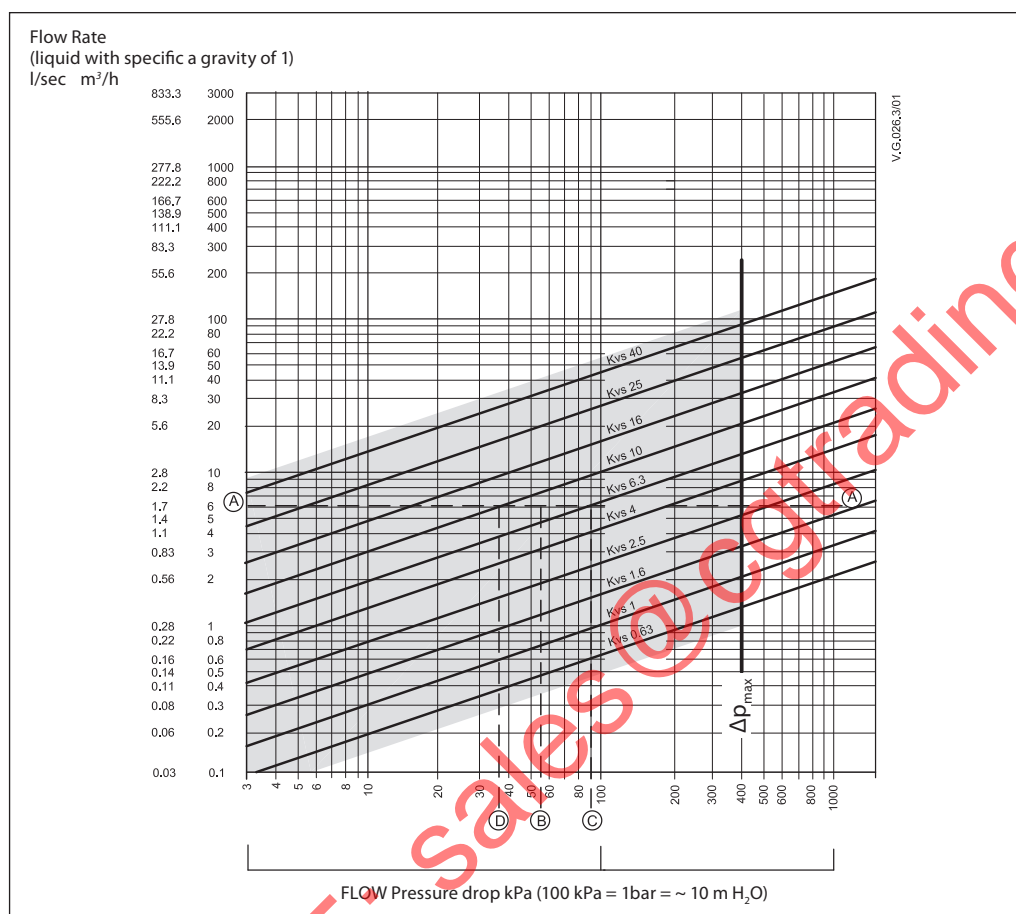

Example

Design data:
Flow rate: 6 m³/h
System pressure drop: 55 kPa

Locate the horizontal line representing a flow rate of 6 m³/h (line A-A). The valve authority is given by the equation:

$$\text{Valve authority, } a = \frac{\Delta p_1}{\Delta p_1 + \Delta p_2}$$

Where:

- Δp₁ = pressure drop across the fully open valve
- Δp₂ = pressure drop across the rest of the circuit with a full open valve

The ideal valve would give a pressure drop equal to the system pressure drop (i.e. an authority of 0.5):

if: $\Delta p_1 = \Delta p_2$
 $a = \Delta p^{1/2} \times \Delta p_1 = 0.5$

In this example an authority of 0.5 would be given by a valve having a pressure drop of 55 kPa at that flow rate (point B). The intersection of line A-A with a vertical line drawn from B lies between two diagonal lines; this means that no ideally-sized valve is available.

The intersection of line A-A with the diagonal lines gives the pressure drops stated by real, rather than ideal, valves. In this case, a valve with k_{vs} 6.3 would give a pressure drop of 90.7 kPa (point C):

$$\text{hence valve authority} = \frac{90.7}{90.7 + 55} = 0.62$$

The second largest valve, with k_{vs} 10, would give a pressure drop of 36 kPa (point D):

$$\text{hence valve authority} = \frac{36}{36 + 55} = 0.395$$

Generally, for a 3 port application, the smaller valve would be selected (resulting in a valve authority higher than 0.5 and therefore improved control). However, this will increase the total pressure and should be checked by the system designer for compatibility with available pump heads, etc. The ideal authority is 0.5 with a preferred range of between 0.4 and 0.7.

Design

(Design variations are possible)

VRG 2

- 1. Valve body
- 2. Valve insert
- 3. Valve cone
- 4. Valve stem
- 5. Moving valve seat (pressure relieved)

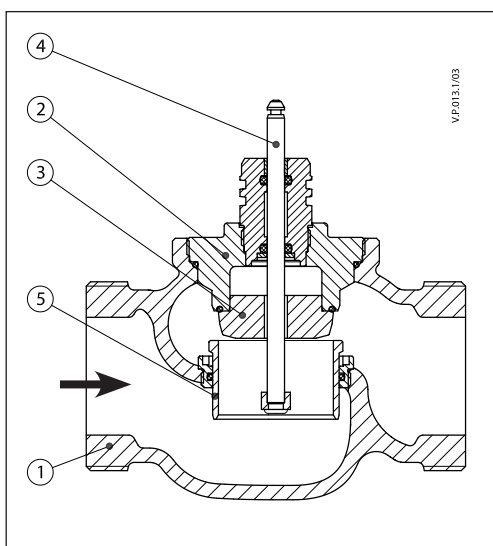

VRG 3

- 1. Valve body
- 2. Valve insert
- 3. Valve cone
- 4. Valve stem
- 5. Valve seat
- 6. Pressure relieve chamber

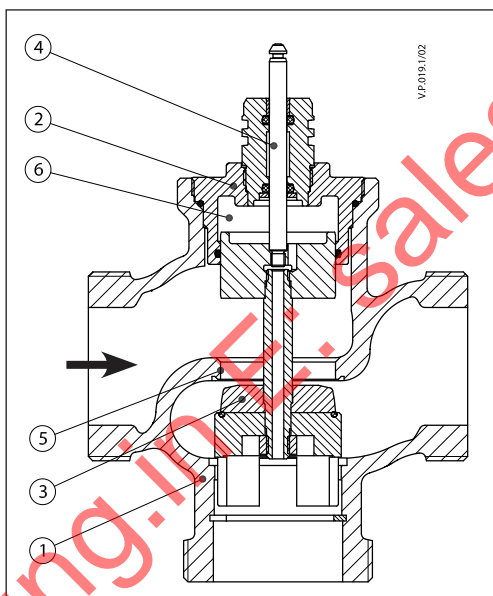

www.cgtrading.in sales@cgtrading.in

Dimensions

AMV(E) 335, 435 + VRG 2,3

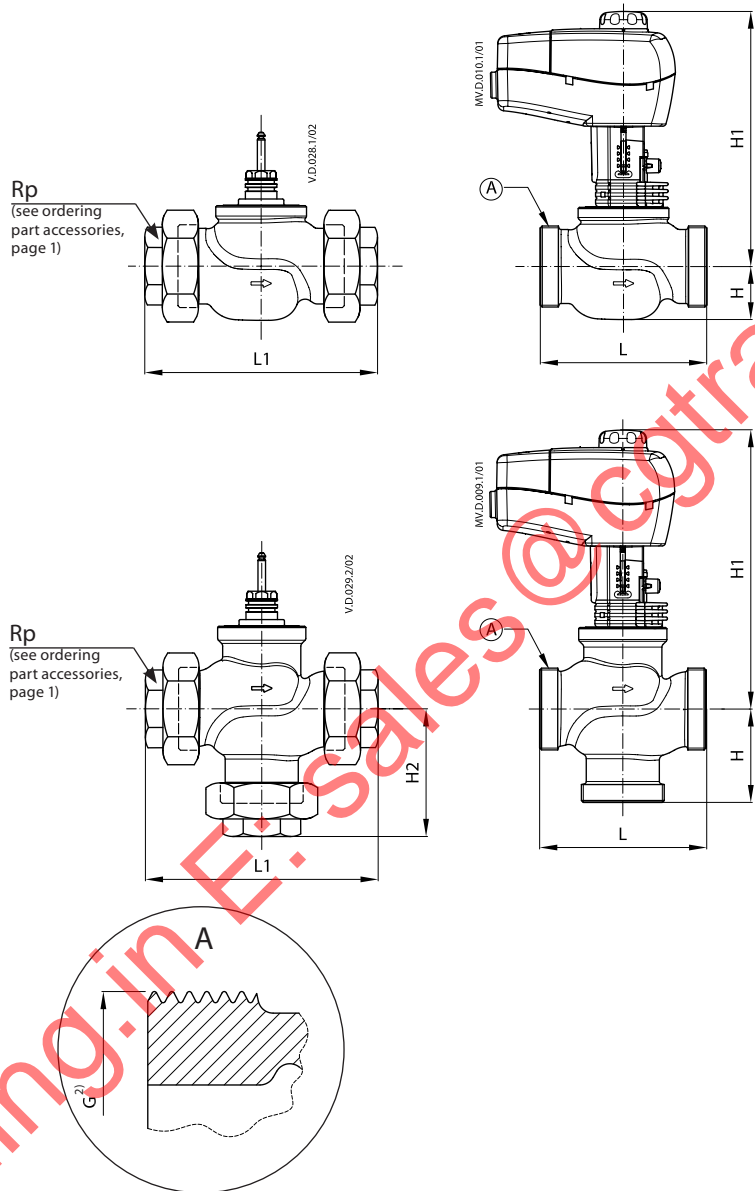

Type	DN	Connection G ¹⁾	L	H	H1	L1	H2	Weight (kg)
VRG 2	15	1	80	25	217	128		0.66
	20	1 1/4	80	29	223	128		0.78
	25	1 1/2	95	29	227	151		1.07
	32	2	112	35	238	178		1.48
	40	2 1/4	132	43	252	201		2.60
	50	2 3/4	160	47	261	234		3.64
VRG 3	15	1	80	40	232	128	64	0.71
	20	1 1/4	80	45	239	128	69	0.90
	25	1 1/2	95	50	248	151	78	1.22
	32	2	112	58	261	178	91	1.82
	40	2 1/4	132	75	302	201	110	3.17
	50	2 3/4	160	83	322	234	120	5.01

¹⁾ G ... external thread DIN ISO 228/01
If stem heater is used dimension H1 is increased for 31 mm.

Dimensions (continued)

AMV(E) 438 SU + VRG 2,3

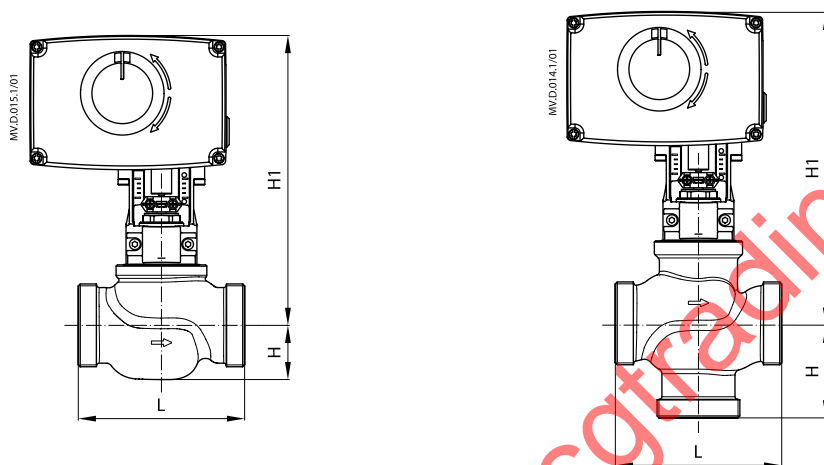

Type	DN	Connection	L	H	H1
		G ¹⁾			
VRG 2	15	1	80	25	237
	20	1¼	80	29	243
	25	1½	95	29	247
	32	2	112	35	258
	40	2¼	132	43	272
	50	2¾	160	47	281
VRG 3	15	1	80	40	252
	20	1¼	80	45	259
	25	1½	95	50	268
	32	2	112	58	281
	40	2¼	132	75	322
	50	2¾	160	83	342

¹⁾ G ... external thread DIN ISO 228/01
If stem heater is used dimension H1 is increased for 5 mm.

www.cgtrading.in E-Mail: sales@cgtrading.in

www.cgtrading.in E: sales@cgtrading.in