

FLANGED BALANCING VALVE

- Precise Double Regulation
- Tamperproof setting with lockshield
- EPDM sealing disc to ensure positive shut-off
- With Pressure Test Cocks
- Facilitates systematic commissioning of the plant for optimal operation
- Available in PN16 and PN20 Rating.

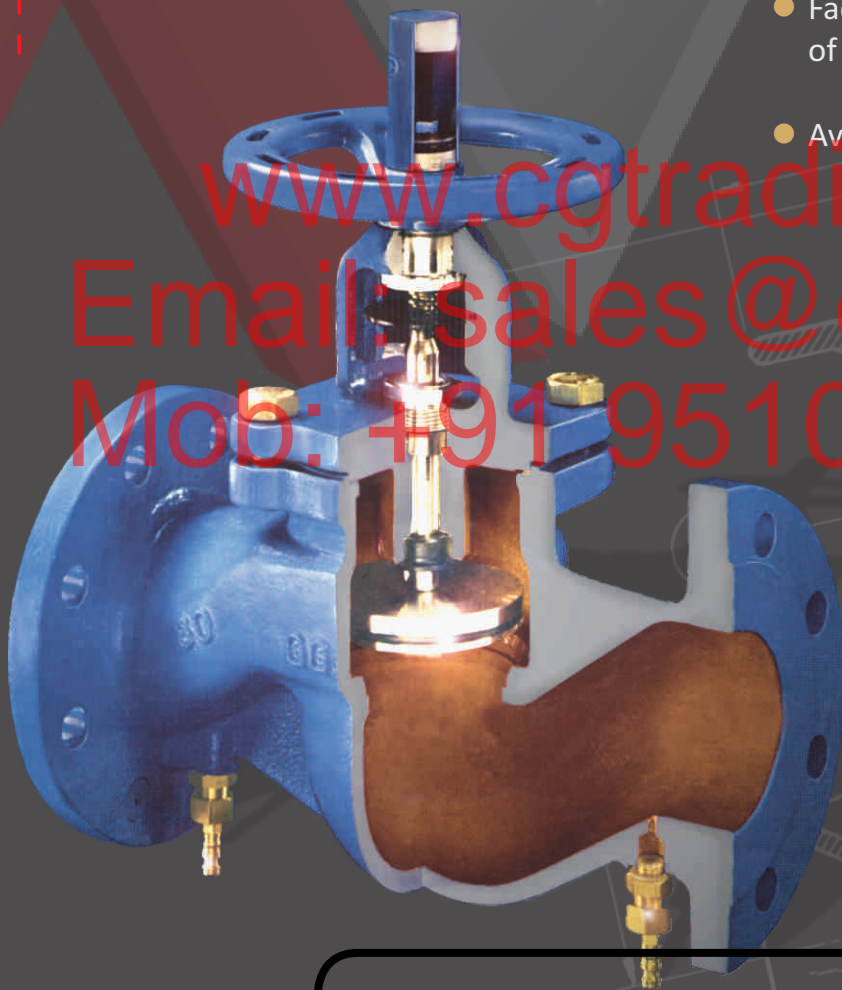

www.cgtrading.in
Email: sales@cgtrading.in
Mob: +91 95101 33345

CG TRADING, SURAT EMAIL: SALES@CGTRADING.IN



Changing the way you think about valves...

CONSTRUCTION AND TECHNICAL INFORMATION

Flanged Manual Balancing Valve are meeting BS 7350 double regulating valve available in sizes DN 80 (3") to DN 300 (12") and pressure rating Pn16 and PN20.

BODY & BONNET : Sturdy construction in Cast Iron as per IS 210 Gr. 260 for PN16, Ductile Iron for Pn20 internally epoxy coated.

DISC : As EN3 steel epoxy coated as standard or SS410 as optional.

SEAT : EPDM as standard or teflon as optional.

STEM SEALING : Special double seal of EPDM as back seat graphite asbestos gland packing.

SPINDLE (STEM) : Non-rising Spindle (Stem) of Stainless Steel Gr. SS 410. The movement of stem can be locked to make tamper proof.

HANDWHEEL : 80mm to 150mm in cast iron to IS 210 Grade FG 260
200mm in cast steel to ASTM A-216 Gr. WCB and
250mm & 300mm in Mild Steel fabricated.

DOUBLE REGULATION : Double regulation by precise and concealed limited stroke, Indicator scale from (fully shut) to fully open, shows handle turns. Additional "Micro Meter Scale" allows fine setting upto 1/10 of a handle wheel turn. After setting the valve as per balancing requirement, the spindle is locked by lock screw thus limiting the maximum operation of valve to preregulated position while still allowing to use as shut-off valve.

MEASUREMENT OF PRESSURE DROP & FLOW RATE : The valves are delivered with two body taps and one set of pressure test quarter turn cocks. Pressure drop across the valve can be measured with specially designed ADVANCE Portable Digital Defferential Pressure Meter, having instant couplings with the pressure test cocks. Pressure test cocks are opened by 1/4 turn using 6mm square double end spanner. Flow can be regulated by turning the wheel. Flow through the valve can be calculated by turning the wheel. Flow through the valve can be calculated by measuring differential pressure across the valve, noting set hand Wheel turns, using the published "K" factor of the valve for different hand wheel turns.

Flow Characteristic are available in the form of Graph as well as in the Computerized format.

The setting thus obtained can be locked by screwing in the lock screw and locking the lock nut which is protected by the lock shield on the hand wheel.

DIRECTION OF FLOW : Direction of the flow is marked on the valve body by an arrow.

APPLICATION : As double regulating, balancing and shut-off valve in hydronic system, In process industry for balancing flow. With special alloys, these valves can be used in Process Plant too for double regulating & flow measurement functions.

TECHNICAL DATA : Standard valves are designed for Maximum operating pressure of 16 bar (225 psi) for liquid temperature not exceeding 120°C (250 °F) with pH values 4 to 9.5. Higher pressure upto PN20 & temperature values can be offered on request.

FLANGED CONNECTION : Flanges are drilled to IS 6392 (PN 16) or to Purchaser's specifications.

TESTING TABLE :

- ♦ Flow/Performance Test ♦ Hydro Testing

	Shell (Body)	Seat
PN-16	24 bar (g)	17.6 bar (g)
PN-20	30 bar (g)	22 bar (g)

MATERIAL SPECIFICATION :

- Body - CI 260 (GG 25)/DI
- Bonnet - CI 260 (GG 25)/DI (IS 1865 Gr. 450/10)
- Hand wheel - CI 220 / WCB / M.S
- Stem - SS 410/431
- Lower Disc - SS-410
- Upper Disc - SS 410
- Body/Bonnet Gasket-CAF
- Body/Bonnet Bolts - A 307 Gr. B
- Gland Packing - Graphited Asbestos
- Steam seal - EPDM
- Seat Seal - EPDM
- Lock Screw
- Counter Nut
- Body Plugs

DIMENSIONS (All) :

Nominal Size	DN mm (Inch)	080 (3")	100 (4")	125 (5")	150 (6")	200 (8")	250 (10")	300 (12")
A	mm	310	350	400	480	600	730	850
Flange OD	mm	200	220	250	285	340	405	460
B	mm	290	410	450	490	590	760	820
ØC	mm	170	222	222	290	385	538	538
Stroke	mm	32	40	49	57	69	80	96
Handwheel Turns		8	10	12	14	13.5	12	14.5
Weight	kg.	27	42	60	84	165	377	460

DIMENSIONS
(All dimensions in mm)

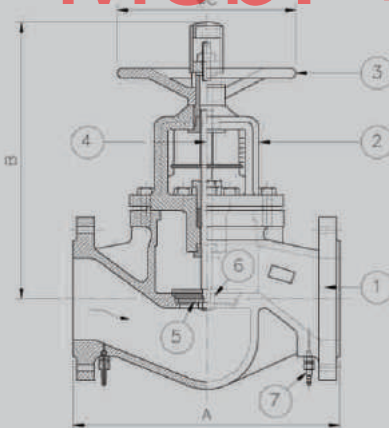

Manufactured & Marketed by