

EXT-MC-TC25

Modulating Temperature Controllers with Digital Display

Features

- Ultra slim wall-mount display control unit to match any decor
- Large easy-to-read liquid crystal display (LCD), with LED backlight (white)
- Stylish bi-directional rotating dial
- Choice of 0-10 VDC or 2-10 VDC outputs via jumper setting
- Retain last entered settings on power resumption
- Dual-output models with auto cooling/heating changeover (deadband operation)
- External and seasonal changeover temperature sensor capability

General

The EXT-MC-TC25 microprocessor-based temperature controllers with digital display provide single or dual 2-10/0-10 VDC proportional control outputs. The controllers are designed for use in heating and cooling applications in air handling units or VAV terminal units, for control of water valves, air dampers and VAV controllers.

The microprocessor combines a proportional plus integral (PI) algorithm with advanced adaptive control logic. The proportional component of the algorithm adjusts the control output in response to changes in the measured temperature. The integral component of the algorithm adjusts the control output to eliminate offset (difference between the set point and the actual temperature). This provides precise and stable control under various system capacity and varying load conditions without the need for tuning or calibrating the control algorithm in the field. The digital display of ambient temperature, set point and operating mode provides the user with an attractive and functional controller that is easy to use.

A bi-directional rotating dial allows change of temperature set point values.

Ordering

To order, specify complete model number.



Figure 1: Model Number Selection Guide

Model Number	Outputs	Output Signal	Applications	Cooling/Heating Mode	External Seasonal Changeover	External Sensor
EXT-MC-TC25-A1	Single	0(2)-10 VDC Proportional	Cool Only or Heat Only (Single-Output System)	Auto by External Device	Yes	Yes
EXT-MC-TC25-A2	Dual	0(2)-10 VDC Proportional	Cooling and Heating (Dual-Output System)	Auto	No	Yes

Figure 2: Dimensions in mm

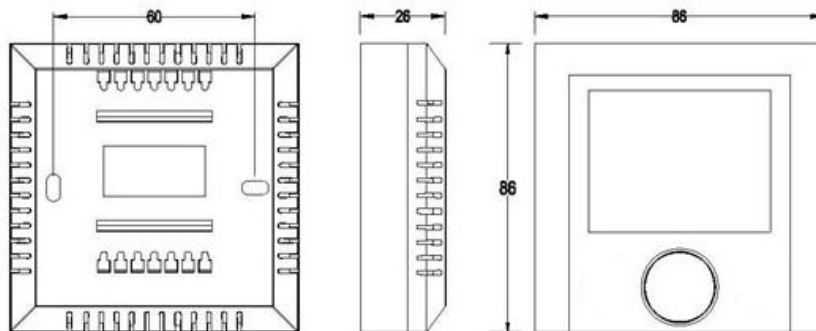

Specifications

Product model numbers	See Figure 1: Model Number Selection Guide
Power requirements	24 V \pm 15%, 50/60 Hz or +24 VDC \pm 10%
Power consumption	1 VA @ 24 VAC
Proportional output	2-10 or 0-10 VDC jumper selectable
Output impedance	Minimum 50,000 Ω
Internal impedance	Maximum 1,000 Ω
Temperature display range	0-40°C in 0.5 K increments: accuracy \pm 1 K
Temperature set point range	5-40°C in 0.5 K increments, initial factory setting 22°C
Constant display on LCD	Ambient temperature
Deadband of dual-output models	Fixed at 1.5 K (\pm 1.5 K of set point value): when ambient temperature is 1.5 K above set point value, controller will go into cooling mode or when ambient temperature is 1.5 K below set point value, controller will go into heating mode.
Proportional band	Fixed at 3 K
Integral time	Fixed at 15 minutes.
Sensor sampling time	10 s
Sensing element	NTC thermistor, 10 k Ω @ 25°C, \pm 1%
Choice of 0-10 or 2-10 VDC output	Via jumper JP2 (factory setting 0-10 VDC)
Unoccupied mode	Input signal from external voltage-free contact, fixed at 16°C for heating and 26°C for cooling
Enclosure	Material: Self-extinguishing, molded ABS Finish: Off white housing and dark grey faceplate
Protective class	IP30
Ambient/Storage temperature limits	0 to 50°C / -30 to 50°C, 10% to 90% RH non-condensing
Electrical ratings	Proportional output: 1 mA at 10 VDC maximum
Connectors	Non-removable screw-type terminal blocks
Power wires	Wire size 1 mm ² or 18 AWG solid copper recommended
Sensor wires	22 AWG twisted shielded pair double-insulated cable
Accessories	See Figure 3: Accessories
Agency approval	CE Mark compliant to EMC Directive pending
Dimensions	See Figure 2: Dimensions in mm
Shipping weight	0.12 kg (0.3 lb)

The performance specifications above are nominal and subject to tolerances and application variables of generally acceptable industry standards. The manufacturer shall not be liable for damages resulting from misapplication or misuse of its products.

Figure 3: Accessories

Description	Part No.
Probe-type Temperature Sensor	01CT-1NH5
Duct-mount Temperature Sensor	01DT-1NN

Figure 4: Cover Removal Procedure

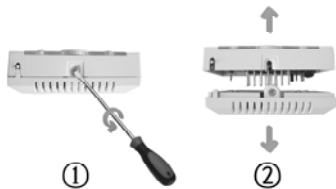

1. Loosen the fixed screw.
2. Slightly twist the screw driver to crack open the cover from the base.
3. Hold the base firmly with one hand and remove the cover with another hand by pulling away from the base forcibly.

Figure 5: Mounting Details

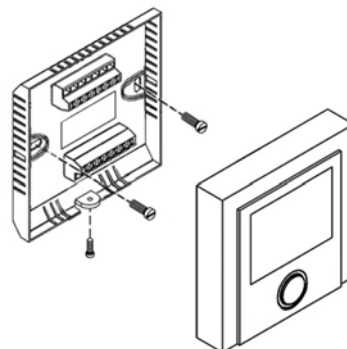

Mounting

The temperature controller can be surface mounted or secured to a standard European 75 x 75 x 35 mm electrical box. See Figure 4: Mounting Details. Two mounting screws are included.

Figure 6: Display Control Unit and LCD Layout

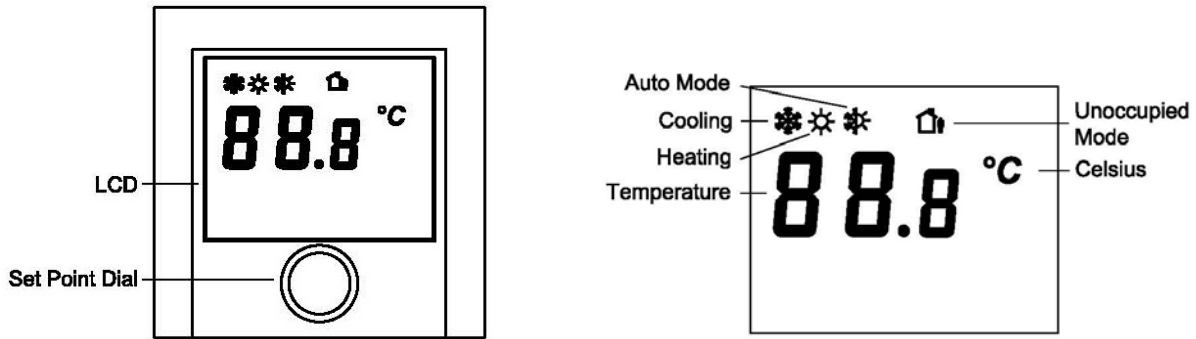
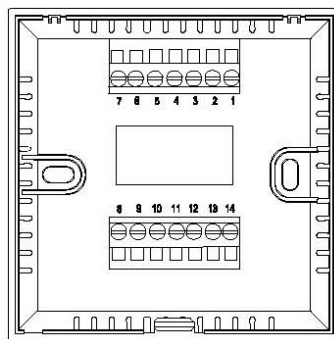
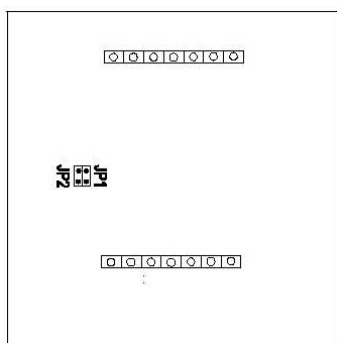

Figure 7: Wiring Terminals and Jumper Settings



JUMPER SETTINGS		
JUMPER NUMBER	JUMPER IN OPEN POSITION	JUMPER IN CLOSED POSITION*
JP1	With External Sensor	With Built-in Sensor
JP2	For 2-10 VDC Output	For 0-10 VDC Output

*Note: * Factory settings*

Controller Errors Reporting

When the following errors are reported on the LED display unit, these errors will prevent the controller from normal operation and all controller functions will be locked out:

- E-1 EEPROM read/write error
- E-2* Temperature sensor open-circuited
- E-3 Temperature sensor short-circuited

* If jumper JP1 is cut open and external sensor is used, E-2 means the external sensor may have been disconnected from Terminals SR1 and GND. Check the external sensor's connectivity and resistive value. If E-2 error is still reported, return the thermostat to the manufacturer for repair.

When the error E-1 or E-3 is reported or when the error E-2 is reported without jumper JP1 being cut and external sensor being installed, return the thermostat to the manufacturer for repair.

Figure 8: Wiring Diagrams



NOTE: Seasonal changeover sensors applicable to TC25-A1 models only

Application Notes

- On a single-output cool only or heat only unit, i.e. a unit with only main output being available, connecting a shunting wire between terminals SR2 and GND forces the unit to go into heating mode.
- On a single-output cool only or heat only unit, connecting a TE10-1 or TE10-2 changeover sensor between terminals SR2 and GND will automatically switch the unit between cooling and heating mode. When the sensor temperature exceeds 30°C, the controller enters into heating mode.
- On a dual-output unit, the main output is always associated with the cooling controlled device and the secondary output with the heating controlled device.
- Move jumper JP1 to open position if external sensor is wired to SR1 and GND.
- Move jumper JP2 to open position if 2-10 VDC proportional output is required.
- The changeover sensor should be wrapped around the supply water pipe when associated with a water system.
- 22 or 24 AWG twisted shielded pair double-insulated cable is recommended as remote sensor wiring and its length must not exceed 25 m.
- Do not bundle and run power wiring and remote sensor wiring in the same conduit.
- Unoccupied contact closure activates unoccupied mode.
- When using either or both of the external temperature and changeover sensors, run the wires away from any electric motors or power wiring. Failure to do so may result in poor thermostat performance due to electrical noise.
- It is highly recommended that the 24 V power supply is interlocked to the air-conditioning system so that the controller is shut down when the air-conditioning system is turned off.

Operation Notes

- The controller is always turned on and in active operating mode when power supply is connected.
- LCD displays ambient temperature constantly. When increasing or decreasing temperature set point value by rotating the adjustment dial clockwise or counter-clockwise, the LCD shows the set point value. Will return to ambient temperature display when the adjustment dial is passive for 5 seconds.
- In unoccupied mode, the factory temperature set points are 26 °C for cooling and 16 °C for heating.
- Unoccupied mode can be activated in the following manner when the unoccupied contact closes:
For single-output models with auto seasonal changeover, the unoccupied cooling or heating mode is determined by the status of the SR2 seasonal changeover sensor and the proportional output is activated according to the measured temperature.
For dual-output models, the unoccupied cooling or heating mode is always determined by the measured temperature and proportional output is also activated according to the measured temperature.
When unoccupied mode is activated, the adjustment dial is locked out and no set point value can be entered.