

Ball Valves



ASME Class 150 to 2500 | 8 mm - 200 mm (1/4" - 8")
ISO 17292/ API 6D



L&T Valves

L&T Valves Limited (Formerly Audco India Limited) is a wholly owned subsidiary of Larsen & Toubro. Backed by a fifty-year track-record of excellence and world-leading innovation, the company provides engineered flow-control solutions for key sectors of the economy such as oil & gas, power, petrochemicals, chemicals, fertilizers and pharmaceuticals.

Product Range:

- Gate, Globe & Check Valves
- Valves for Power
- Pipeline & Process Ball Valves
- Triple-offset Butterfly Valves
- Flanged & Wafer-type Butterfly Valves
- Double Block and Bleed Plug Valves
- Control Valves
- Customised Solutions

Designs for the valves are created by an experienced team of valve experts who have a deep understanding of user-industry processes. An extensive manufacturing and quality assurance infrastructure ensure that world-class designs are transformed into high performance products. Every phase of manufacture is governed by an institutionalised environment, health and safety policy.

L&T Valves marketing network spans the globe reinforced by strategic alliance with key international distributors. In India, the company has a presence in every industrial centre through a network of offices, field engineers, distributors, automation centres and service franchisees.



- Single-piece Range - Page No. 9
- Two-piece Range - Page No. 10
- Three-piece Range - Page No. 12



L&T Valves manufactures a comprehensive range of Ball Valves in sizes up to 8" (DN 200) and in ASME classes from 150 to 2500. The valves are offered in combination of size, pressure class, material of construction, end-connection, etc., to suit myriad applications in process plants, utility lines and HVAC.

Product Portfolio

Valve	Type	End Connection	¼	⅜	½	¾	1	1¼	1½	2	2½	3	4	6	8
			8	10	15	20	25	32	40	50	65	80	100	150	200
Single-piece, Regular Bore	Fire-safe	Flanged CI 150/ 300			•	•	•		•	•	•	•	•	•	•
Two-piece, Full Bore	Fire-safe	Flanged CI 150/ 300			•	•	•		•	•	•	•	•	•	•
Two-piece, Regular Bore	Fire-safe	Flanged CI 150/ 300							•	•	•	•	•	•	•
Three-piece, Full Bore		Screwed/ Socket-weld*	•	•	•	•	•	•	•	•	•	•	•		
	Standard	Flanged CI 150/ 300/ 600			•	•	•		•	•					
		Flanged CI 2500			•	•	•		•						
	Fire-safe	Screwed/ Socket-weld*	•	•	•	•	•	•	•	•	•				
Three-piece, Regular Bore	IBR	Screwed/ Socket-weld	•	•	•	•	•	•	•	•					
	Standard	Screwed/ Socket-weld**	•	•	•	•	•	•	•	•		•	•		
		Flanged CI 150/ 300/ 600				•	•		•	•					
		Flanged CI 1500			•	•	•		•	•					
	Fire-safe	Screwed/ Socket-weld*				•	•	•	•	•					
	IBR	Screwed/ Socket-weld				•	•	•	•	•					

*Screwed/ socket-weld valves in sizes DN 8 to DN 50 are offered in Class 800, and sizes DN 65 and above, in Class 300.

**Sizes DN 15 to DN 50 are offered in Class 1500 also.

L&T Ball Valves are available in single-piece, two-piece and three-piece constructions. In these valves, line pressure forces the floating ball against the downstream seat to effect bubble-tight sealing.

Blowout Proof Stem

The side-entry stem of L&T Ball Valves has a shoulder that bears against a matching shoulder in the body to make it blowout proof - the higher the line pressure, the better the sealing to atmosphere.

High Integrity Stem Sealing

Sealing to atmosphere is further enhanced by stem thrust seals and stem packing rings. To compensate for wear and thermal expansions, Belleville springs are used.

Inserts in single-piece Ball Valves are provided with a hexagonal slot for easy removal.



Mirror-finished Solid Stainless Steel Balls

To obtain bubble-tight sealing and lower operating torques, mirror-finished SS balls are used as a standard. The solid construction of the balls guarantees higher structural strength.

Seats with Pressure-relieving Slots

Seats with fine grain structure are used to ensure better strength and longer life. Pressure-relieving slots are a unique feature of L&T Ball Valves. The slots relieve upstream pressure when the valve is in closed position and prevent seat damage.

Actuator Mounting Flange

L&T single-piece and two-piece Ball Valves are provided with an integral actuator mounting flange conforming to ISO 5211.

Please note that full bore valves in sizes DN 15 to DN 25 would be supplied with mounting arrangement as per L&T's manufacturing standard.

Fire-Safe Feature

L&T fire-safe Ball Valves feature secondary metal seats. In the event of a fire, after the soft-seat totally sublimates, the ball moves and abuts the downstream metal seat to form a leak-tight seal.



Antistatic Feature

Static electricity builds up inside a valve when the ball rubs against non-metallic seats. This is a fire hazard, especially in flammable fluid pipelines. L&T Ball Valves have inbuilt antistatic mechanisms to provide electrical continuity.

Stems of full bore valves of size 65 mm and above and regular bore valves of size 80 mm and above are equipped with spring-loaded plungers. In valves of smaller sizes, electrical continuity is achieved by using Carbon-filled PTFE thrust seal and graphite stem packings.

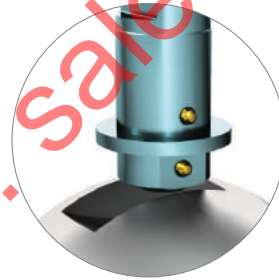

Cavity Pressure Relief Mechanism

A slight increase in temperature of fluid entrapped in ball cavity can cause a rapid increase of pressure and damage the ball and seats.

To prevent this, L&T Ball Valves are equipped with automatic cavity relief mechanisms. When the valve is in open position, a hole provided on the ball connects the body cavity to the ball port and thereby ensure that cavity pressure does not build up. In the closed condition, when the cavity pressure rises above a designated level, the seat lip deflects to relieve pressure to the upstream side.

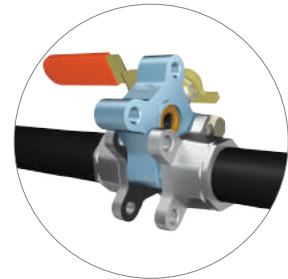

On-line Service

Three-piece Ball Valves are designed for easy on-line service. To access the valve internals, remove three connector bolts and swing the body out using the fourth bolt as a pivot.

Standards

Scope	Standard	
Design*	ISO 17292/ API 6D	
End-to-End	Socket-weld ends	ASME B16.11
	Screwed-end BSPT	ISO 7-1
	Screwed-end NPT	ASME B1.20.1
	End flange	ASME B16.5 RF/ FF/ RTJ
Face-to-face (Flanged)	ASME B16.10	
Pressure testing	ISO 5208/ API 598	
Fire Test	ISO 10497/ API 607	

*Valve with API 6D design can be offered on demand

Material of Construction

No.	Part	Material specification		
		Single-piece	Two-piece	Three-piece
1	Body/ Connector/ Insert	ASTM A216 Gr. WCB		ASTM A216 Gr. WCB ASTM A105
		ASTM A351 Gr. CF8M/ ASTM A182 Gr. F316		
2	Ball	ASTM A351 Gr. CF8M/ ASTM A182 Gr. F316/ ASTM A182 Gr. F304		
3	Seat	PTFE/ RPTFE/ Special filled PTFE/ PEEK/ Devlon®/ NXT-70/ SS316 + ST		
4	Stem	ASTM A479 Type 316		
5	Body Seal	Graphite		PTFE/ RPTFE/ Special filled PTFE/ Graphite
6	Stem Thrust Seal	Carbon-filled PTFE		
7	Stem Packing	Carbon-filled PTFE/ Graphite		

Pressure Temperature Charts - Seat Materials

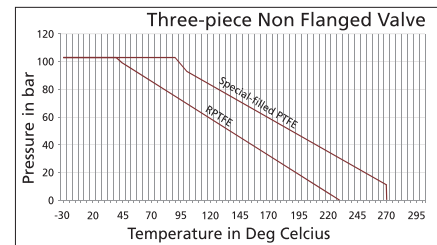
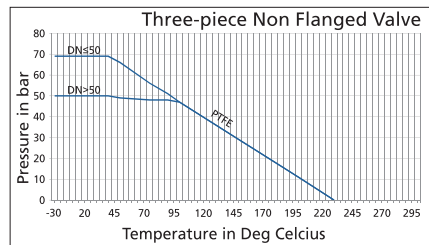
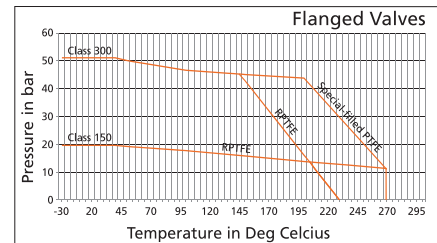
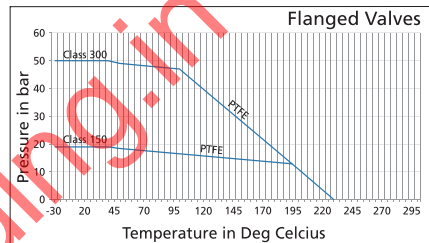

Test Pressures (bar)

	Class 150	Class 300	Class 600*
Shell - Hydrostatic	30	77	155
Seat - Hydrostatic	22	56	113
Seat - Pneumatic	5.5	5.5	5.5

*With RPTFE/ Special filled PTFE

Valve Torque Data (in Nm)

Size		Bore	Single-piece		Two-piece		Three-piece		
DN	NPS		Flanged Cl 150	Flanged Cl 300	Flanged Cl 150	Flanged Cl 300	Screwed/Socket-weld	Flanged Cl 150	Flanged Cl 300
8	¼	FB					6.5		
		RB							
10	⅜	FB					6.5		
		RB							
15	½	FB	5	5	9	9	6.5	5	5
		RB							
20	¾	FB			9	9	9	8	9
		RB	5	5			6.5	5	5
25	1	FB			14	16	11	10	11
		RB	12	15			9	8	9
32	1¼	FB					30		
		RB					16		
40	1½	FB			25	28	34	18	32
		RB	18	22			13	13	13
50	2	FB			65	70	44	26	30
		RB	38	40			34	30	32
65	2½	FB			90	98			
		RB	48	60					
80	3	FB			150	165			
		RB	90	100					
100	4	FB			165	185			
		RB	145	160					
150	6	FB			250	350			
		RB	165	190					
200	8	FB			650	750			
		RB							

For screwed/ socket-weld end three-piece valves, torque values are as per full-rated working pressure of 69 bar. Indicated design torque values are without factor of safety. Torque values for other sizes/ classes will be provided on demand.

Flow Co-efficients

	Bore	8	10	15	20	25	32	40	50	65	80	100	150	200
C _v	FB	8	9	20	50	100	135	225	465	770	1090	1970	4635	8565
	RB				15	40	60	95	175	335	570	625	870	2300
K _v	FB	7	8	17	45	85	115	220	395	655	930	1675	3940	7280
	RB				13	35	50	80	150	285	485	530	740	1955

C_v - Flow Co-efficient of a valve is defined as flow of water at 15.6°C (60°F) in gallon (US) per minute at a pressure drop of 1 psi across the valve. K_v - Flow Co-efficient of a valve is defined as flow of water with temperature ranging from 5°C (40°F) to 40°C (104°F) in cubic meter per hour (m³/hr) at a pressure drop of 1 bar across the valve. C_v and K_v values are given for valve in fully open condition.

End Connection Identification

Grooves are provided on body connectors to differentiate valves based on end connections - one groove for socket-weld ends, two grooves for valves with screwed ends (NPT threads) and no grooves for valves with screwed ends (BSPT threads).



www.cgtrading.in E: sales@cgtrading.in

Single-piece Ball Valves - Regular Bore (ASME Class 150 & 300)

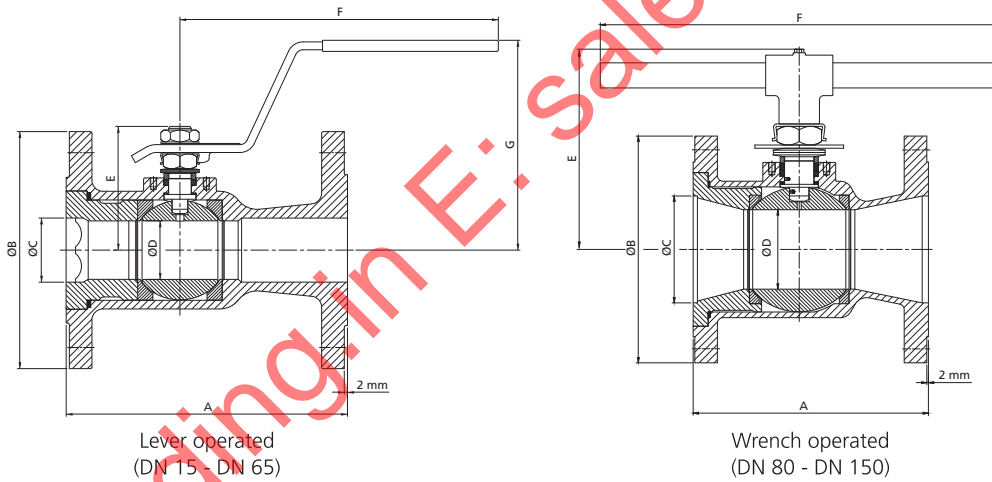

Dimensions

Size		A		B		C	D	E	F	G	Wt.		ISO 5211 Base	
DN	NPS	CI 150	CI 300	CI 150	CI 300						CI 150	CI 300	CI 150	CI 300
15	½	108	140	90	95	13	11	38	120	90	1	2	F03	F03
20	¾	117	152	100	115	19	11	38	120	90	1	2.5	F03	F03
25	1	127	165	110	125	25	17	46	140	100	2	4	F03	F03
40	1½	165	190	125	155	38	27	56	180	115	4	4.5	F04	F04
50	2	178	216	150	165	51	37	75	210	122	6.5	9	F05	F05
65	2½	190	241	180	190	64	49	102	210	142	11	15	F07	F07
80	3	203	282	190	210	76	62	175	390		15.5	22	F07	F07
100	4	229	305	230	255	102	74	195	390		25	35	F07	F07
150	6	267	403	280	320	152	98	245	*		40	65	F10	F12

All dimensions in mm and weights in kg
 *600 mm for CI 150 & 890 mm for CI 300

Two-piece Ball Valves - Full Bore (ASME Class 150 & 300)

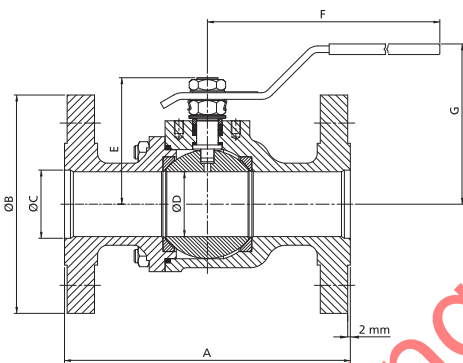

Lever operated
(DN 15 - DN 50)

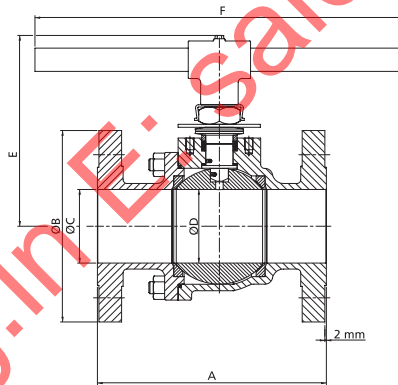

Wrench operated
(DN 65 - DN 200)

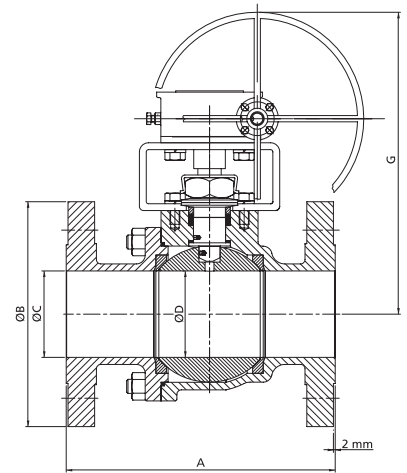

Gear operated
(DN 100 - DN 200)

Dimensions

Size		A		B		C	D	E		F	G	Wt.		ISO 5211 Base	
DN	NPS	CI 150	CI 300	CI 150	CI 300			CI 150	CI 300			CI 150	CI 300	CI 150	CI 300
15	1/2	108	140	90	95	13	11	38	38	120	90	1	2		
20	3/4	117	152	100	115	19	17	45	45	120	97	2	3		
25	1	127	165	110	125	25	24	55	55	158	97	3	4		
40	1 1/2	165	190	125	155	38	37	75	75	212	122	5	6	F05	F05
50	2	178	216	150	165	51	49	103	103	212	142	9	12	F07	F07
65	2 1/2	190	241	180	190	64	62	175	175	390		14	20.5	F07	F07
80	3	203	282	190	210	76	74	185	195	390		19	28	F07	F07
100	4	229	305	230	255	102	98	235	247	*		31	45	F10	F12
150	6	394	403	280	320	152	148	285	315	**		78	105	F12	F14
200	8	457	502	345	380	203	198	345	371	980		141.5	169	F14	F16

All dimensions in mm and weights in kg

*600 mm for CI 150 & 890 mm for CI 300

**890 mm for CI 150 & 980 mm for CI 300

API 6D design available on demand. Also metal-seated valves in sizes up to DN 80.

Two-piece Ball Valves - Regular Bore (ASME Class 150 & 300)

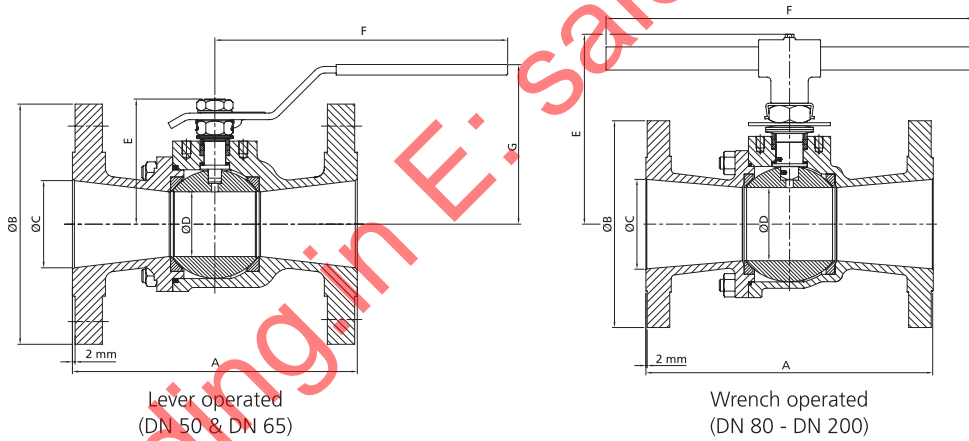
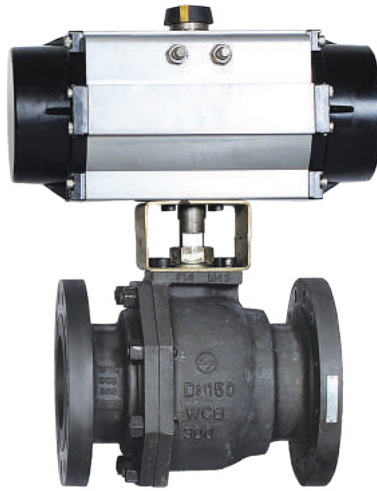

Dimensions

Size		A		B		C	D	E		F	G	Wt.		ISO 5211 Base	
DN	NPS	CI 150	CI 300	CI 150	CI 300			CI 150	CI 300			CI 150	CI 300	CI 150	CI 300
50	2	178	216	150	165	51	37	75	75	212	122	7	10	F05	F05
65	2½	190	241	180	190	64	49	103	103	212	142	12	17	F07	F07
80	3	203	282	190	210	76	62	175	175	390		20	24	F07	F07
100	4	229	305	230	255	102	74	185	195	390		28	45	F07	F07
150	6	394	403	280	320	152	98	235	247	600		52	5	F10	F12
200	8	457	502	345	380	203	148	285	315	890		95	142	F12	F14

All dimensions in mm and weights in kg

Three-piece Ball Valves - Full Bore (ASME Class 150, 300, 600 & 2500)

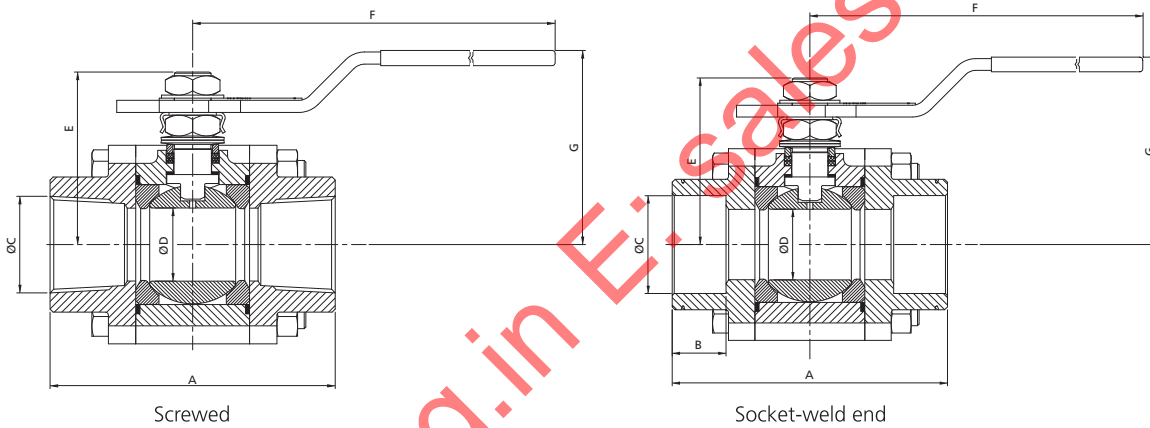

Dimensions

Screwed/ Socket-weld end

Size		A	B	C			D	E	F	G	Wt.
DN	NPS			SW	BSPT	NPT					
8	¼"	62	9.5	14.6 - 14.2	¼" - 19	¼" - 18	11	38	132	50	1
10	⅜"	62	9.5	18.0 - 17.6	⅜" - 19	⅜" - 18	11	38	132	50	1
15	½"	66	10	22.2 - 21.8	½" - 14	½" - 14	11	38	132	50	1
20	¾"	75	13	27.6 - 27.2	¾" - 14	¾" - 14	17	46	132	58	1
25	1"	92	13	34.3 - 33.9	1" - 11	1" - 11½	24	54	162	65	2
32	1¼"	114	13	43.1 - 42.7	1¼" - 11	1¼" - 11½	37	75	192	83	4
40	1½"	114	13	49.2 - 48.8	1½" - 11	1½" - 11½	37	75	192	83	4
50	2"	132	16	61.7 - 61.2	2" - 11	2" - 11½	49	87	202	94	6
65	2½"	185	16	74.4 - 73.9	2½" - 11	2½" - 8	62	200	390	200	15.5
80	3"	208	16	90.3 - 89.8	3" - 11	3" - 8	74	225	390	225	25
100	4"	240	19	115.7 - 115.2	4" - 11	4" - 8	98	250	600	250	39

Cold Working Pressure (CWP)
 - 69 bar, with PTFE seat
 - 103 bar, with RPTFE and special filled PTFE
 - 400 bar, with Devlon®
 - 425 bar, with PEEK

All dimensions in mm and weights in kg

Screwed/ socket-weld valves in sizes DN 8 to DN 50 have a body rating of Class 800. In larger sizes, the body is rated to Class 300.

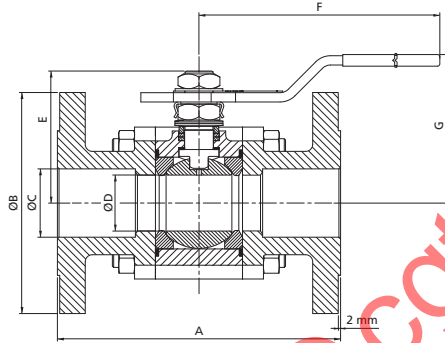

Dimensions

Flanged end - Class 150, 300 & 600

Size		A			B			C	D	E	F	G	Wt.		
DN	NPS	CI 150	CI 300	CI 600	CI 150	CI 300	CI 600						CI 150	CI 300	CI 600
15	½	108	140	165	90	95	95	13	11	38	122	92	2	2	2.5
20	¾	117	152	190	100	115	115	19	17	46	142	98	2	3	3.5
25	1	127	165	216	110	125	125	25	24	54	152	98	3	5	6.5
40	1½	165	190	241	125	155	155	38	37	75	212	125	8	11	12
50	2	178	216	292	150	165	165	51	49	87	212	125	13	15.5	12.5

All dimensions in mm and weights in kg

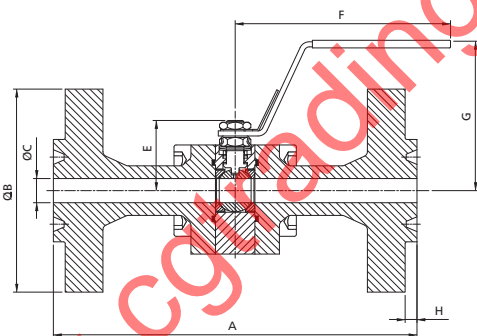

Lever operated
(DN 15 - DN 25)

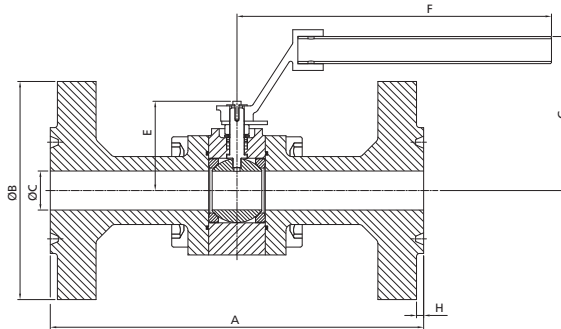

Wrench operated
(DN 40)

Flanged end - Class 2500

Size		A	B	C	E	F	G	H	Wt.
DN	NPS								
15	½	264	135	14.3	50	195	103	6.35	10
20	¾	273	140	20.6	66	250	125	6.35	14
25	1	308	160	25.3	92	360	153	6.35	25
40	1½	386	205	38.5	100	315	162	7.92	40

All dimensions in mm and weights in kg

Three-piece Ball Valves - Regular Bore (ASME Class 150, 300, 600 & 1500)

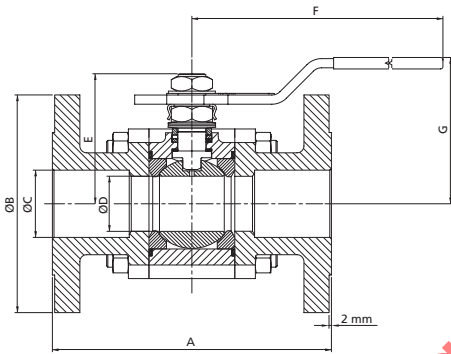

Class 150, 300 & 600

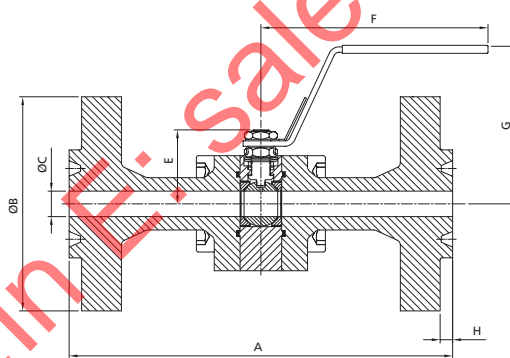

Class 1500

Dimensions

Flanged end - Class 150, 300 & 600

Size		A			B			C	D	E	F	G	Wt.		
DN	NPS	Cl 150	Cl 300	Cl 600	Cl 150	Cl 300	Cl 600						Cl 150	Cl 300	Cl 600
20	¾	117	152	190	100	115	115	19	11	38	122	92	1.8	3.0	4
25	1	127	165	216	110	125	125	25	17	46	142	98	2.5	4.2	5.5
40	1½	165	190	241	125	155	155	38	27	56	180	117	4.7	8.0	9.5
50	2	178	216	292	150	165	165	51	37	75	212	125	7.7	12.1	10.5

All dimensions in mm and weights in kg

Flanged end - Class 1500

Size		A	B	C	E	F	G	H	Wt.
DN	NPS								
15	½	216	120	14.3	41	120	88	6.35	7
20	¾	229	130	14.3	41	120	88	6.35	8
25	1	254	150	20.6	54	235	120	6.35	10
40	1½	305	180	25.4	54	235	127	6.35	18
50	2	368	215	38.5	93	450	157	7.92	27

All dimensions in mm and weights in kg

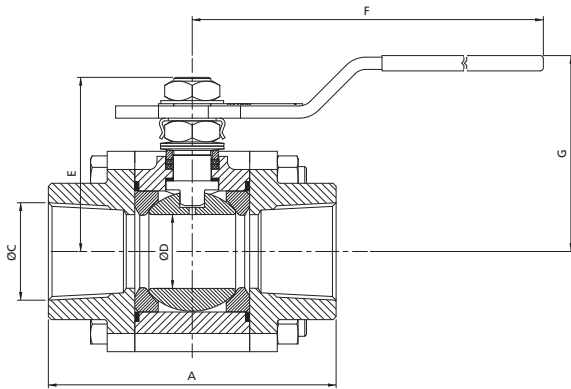

Screwed

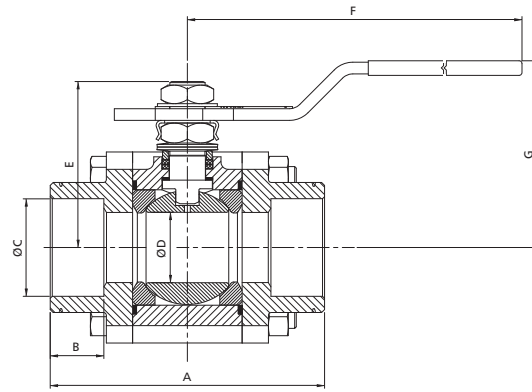

Socket-weld end

Dimensions

Screwed/ Socket-weld end

Size		A	B	C			D	E	F	G	Wt.
DN	NPS			SW	BSPT	NPT					
8	¼	62	9.5	14.6 - 14.2	¼" - 19	¼" - 18	11	38	132	50	1
10	⅜	62	9.5	18.0 - 17.6	⅜" - 19	¾" - 18	11	38	132	50	1
15	½	66	10	22.2 - 21.8	½" - 14	½" - 14	11	38	132	50	1
20	¾	69	13	27.6 - 27.2	¾" - 14	¾" - 14	11	38	132	50	1
25	1	90	13	34.3 - 33.9	1" - 11	1" - 11½	17	46	132	58	1
32	1¼	97	13	43.1 - 42.7	1¼" - 11	1¼" - 11½	24	54	162	65	2
40	1½	103	13	49.2 - 48.8	1½" - 11	1½" - 11½	27	56	162	66	2.5
50	2	122	16	61.7 - 61.2	2" - 11	2" - 11½	37	75	192	83	4.5
80	3	185	16	90.3 - 89.8	3" - 11	3" - 8	62	200	390	200	17
100	4	212	19	115.7 - 115.2	4" - 11	4" - 8	74	225	600	225	27

Cold Working Pressure (CWP)
 - 69 bar, with PTFE seat
 - 103 bar, with RPTFE and special filled PTFE
 - 400 bar, with Devlon®
 - 425 bar, with PEEK

All dimensions in mm and weights in kg

Valves in sizes DN 8 to DN 15 are offered in full bore construction

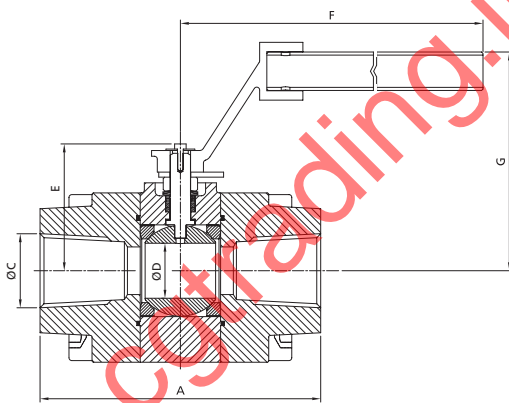

Screwed

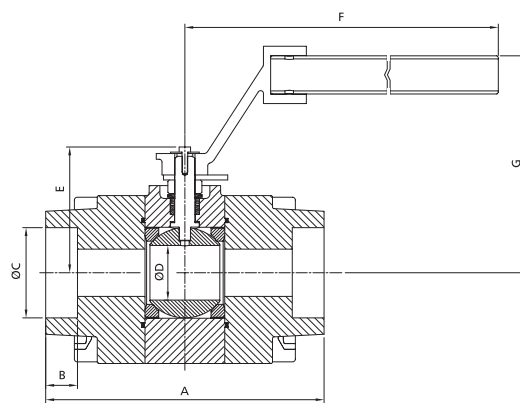

Socket-weld end

Screwed/ Socket-weld end - Class 1500

Size		A	B	C			D	E	F	G	Wt.
DN	NPS			SW	BSPT	NPT					
15	½	85	10.5 - 10.0	22.2 - 21.8	½" - 14	½" - 14	14.3	41	120	52	3
20	¾	85	13.5 - 13.0	27.6 - 27.2	¾" - 14	¾" - 14	14.3	41	120	52	3.5
25	1	108	13.5 - 13.0	34.3 - 33.9	1" - 11	1" - 11½	20.6	54	130	90	4
40	1½	125	13.5 - 13.0	49.2 - 48.8	1½" - 11	1½" - 11½	25.4	54	130	90	5
50	2	142	16.5 - 16.0	61.7 - 61.2	2" - 11	2" - 11½	38.5	88	210	155	6

All dimensions in mm and weights in kg

Ordering Information

Series	Type	Bore	Ends*	Material	Option	Operator
L	1 - Single-piece	F - Full	BT - BSPT Threaded	C - Carbon Steel	F - Fire-safe	Lever/ Wrench
	2 - Two-piece	R - Regular	NT - NPT Threaded	S - Stainless Steel		Gear Unit
	3 - Three-piece		SW - Socket-weld	D - Duplex SS	Pneumatic	
	4 - Two-piece (API 6D)		SN - SW NPT		Electrical	
	5 - Two-piece (IBR)		F1 - Flanged CI 150			
	6 - Three-piece (IBR)		F3 - Flanged CI 300			
	8 - Three-piece - Pharmaceutical		F4 - Flanged CI 150 Flat Face			
			F5 - Flanged CI 300 Flat Face			
			F6 - Flanged CI 600 (RF 125-250)			
			F9 - Flanged CI 1500 (RF 125-250)			
		FA - Flanged CI 1500 (RTJ)				
		FR - Flanged CI 2500 (RF 125-250)				
		FC - Flanged CI 2500 (RTJ)				

*Valves with other ends available on demand



L&T Valves

L&T Valves Limited

Mount - Poonamallee Road, Manapakkam, Chennai 600 089, INDIA

Tel: + 91 44 2249 2323 Email: ContactUs@Lntvalves.com www.Lntvalves.com CIN Number: U74999MH1961PLC012188

Registered Office: L&T House, N. M. Marg, Ballard Estate, Mumbai - 400 001, INDIA

Publication Number: VC001-R3/0115

As we continuously endeavour to improve our products, the data given herein is subject to change.
Please refer www.Lntvalves.com for the latest publication.

