

ML7421A/B SERIES SMART LINEAR VALVE ACTUATOR

PRODUCT DATA



ML7421A

ML7421B

FEATURE

- Easy and quick installation
- No separate linkage and adjustments required
- Low power consumption and maintenance-free
- Self-adaption function
- Force-limiting end stops
- Manual operation knob
- 0(2)~10 Vdc input and 2~10 Vdc position feedback
- Direct/ Reverse action adjustable
- Selectable stroke position when signal failure
- Corrosion-resistant design

SPECIFICATION

Temperature

Ambient operating	-10~+50°C at 5~95% r.h.
Ambient storage	-40...+70 °C at 5...95% r.h.
Medium temperature	150 °C max. (220 °C with High-Temperature kit)

Signals

Signal input	y=0(2)~10 Vdc or 4~20 mA
Input impedance	for voltage Ri=100 KΩ for mA Ri=500Ω
Position feedback signal	x=2~10Vdc
Output impedance	1 KΩ max.
Output load	1 mA max.

Safety

Protection	class III as per EN60730-1
Protection standard	IP54 as per EN60529
Flame retardant	housing V0 as per UL94 (with metal cable gland)

Material

Cover	ABS-FR
Yoke and Base	Aluminum die-cast

GENERAL

The ML7421A / ML7421B actuators are designed for modulating control, accepting 0(2)...10v or 4...20mA input signal, and providing feedback signal 2...10 Vdc only.

They operate Honeywell's standard valves in heating, ventilation, and air conditioning (HVAC) applications.

WIRING

Wiring terminal	1.5 mm ²
Cable entry	M20

Table 1. Selection

Model Number	ML7421A8035-E	ML7421B8012-E
Power supply	24 Vac ±15%; 50/60 Hz	
Power consumption	14 VA	
Input signal: 0(2) Vdc	Actuator stem retracted. 2-way valve: "OPEN"; 3-way valve port A-AB: "CLOSED" ①	
Input signal: 10 Vdc	Actuator stem extended. 2-way valve: "CLOSED"; 3-way valve port A-AB: "OPEN" ①	
Feedback signals	2-10Vdc	
Stroke	20mm	38mm
Runtime (50 Hz)	1.9min	3.5min
Output force	≥ 1800N	
Weight	2.0Kg	2.0Kg

① Factory default setting. It can be reversed by pushing button W3 on circuit board (see Fig. 1).

OPERATION

General

The drive of a synchronous motor is converted into linear motion of the actuator stem by using a worm gear transmission. The actuator stem is connected with the valve stem by a button-keyed retainer connection.

Via installed micro switches, the internal force sensor switches off the actuator precisely when the nominal stem force is reached.

Manual Operation

Actuators are equipped with a manual operation knob used in case of power failure. Manual operation is possible only after the power supply is switched off or disconnected.

To operate, push the manual operation knob down and turn clockwise to move the stem upward and counterclockwise to move the stem downward. If the actuator returns to automatic control, the manual operation knob unlocks automatically.

NOTE: Manual operations allows a very high closing force causing actuator spindle jamming so that the motor can not move. Therefore, after a manually close-off operation, it is necessary to release the spindle one turn by turning the manual operator knob, thus ensuring that the manual operator will automatically disengage on power resumption.

Electrical Installation

The actuators are delivered with a pre-installed cable gland M20. To avoid malfunction, it is necessary to connect 24 Vac power and ground (see wiring).

Max. cable length/diameter for field mounting: 200 m / 1.5 mm²

Self-adaption mode

Power on actuator with 24Vac.

Manual adaption

Press down buttons W2 and W3 at the same time and hold more than 2s, till LED begins to flash, and actuator starts the process of stroke mapping.

The actuator will work one whole cycle (Full Close and Full Open) automatically. When the LED stops flashing, it means the self-adaption is completed. The actuator will return to the position at which the actuator started the self-adaption.

Signal adaption

Input 0V signal, actuator moves to Full Open (top position), the upper limit is calibrated; input 10V signal, actuator moves to Full Close (bottom position), the lower limit is calibrated; Upon both directions checked, the stroke adaption is done.

NOTE: the time taking on stroke adaption depends on actuator's runtime (see Table 1).

Input Signal Selection

Input signal Y can be selected by button **W2** (see Fig. 1). When LED on, signal is 0...10 Vdc (factory default); when LED off, input signal is 2...10 Vdc.

To accept 4~20mA input signal, please change the position of jumper plug **W4** to the right-hand side (Note LED for W2 must be OFF).

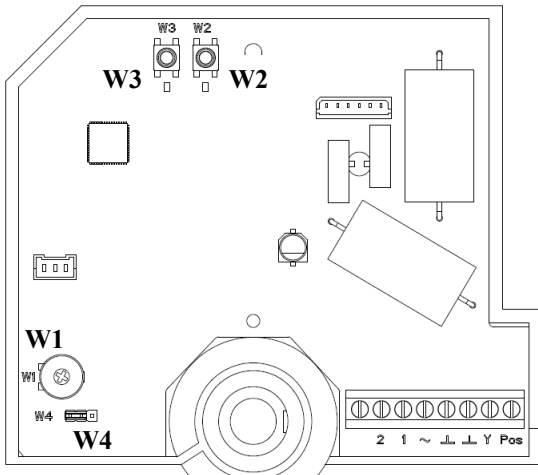

Fig 1. Circuit Board Layout

Feedback Signal

Feedback signal is only 2...10 Vdc, which represents actuator actual position. When the valve is at the lowest position, the feedback signal is 10V(factory default).

Close-off Pressure

Output force		1800 N								
Stroke		20mm						38mm		
Valve size	mm	25	32	40	50	65	80	100	125	150
	inch	1	1 ¼	1 ½	2	2 ½	3	4	5	6
Valve model		Close-off pressure (kPa)								
V5011P		1600	1600	1500	850					
V5328A					1200	1000	1000			
V5216A (DN50~80)					1200	1000	1000			
V5216 (DN100~150)								850	850	850
V5088A								850	850	850
V5013P			1600	1500	850					
V5329A						600	400			
V5050A								150	120	80

Input Signal Failure

In case of a signal input e.g. a broken wire, the actuator will run to one of the three positions 0%, 50% or 100% of full stroke. The factory setting of W1 is "50%" (see Fig. 2). W1 can be set with a screwdriver.

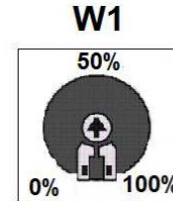

Fig 2. Potentiometer

Moving Direction

The moving direction can be reversed by pressing button **W3** (see Fig. 1). When LED is ON, input signal 0(2) Vdc represents the upper limits (factory default); when LED is OFF, input signal 0(2) Vdc represents the lower limit.

High Temperature Kit

(medium temperature 150°C ~220°C)

Part Number

4319600-001 (20mm)

4319600-002 (20mm)

43196000-038 (38mm)

Dimension (mm)

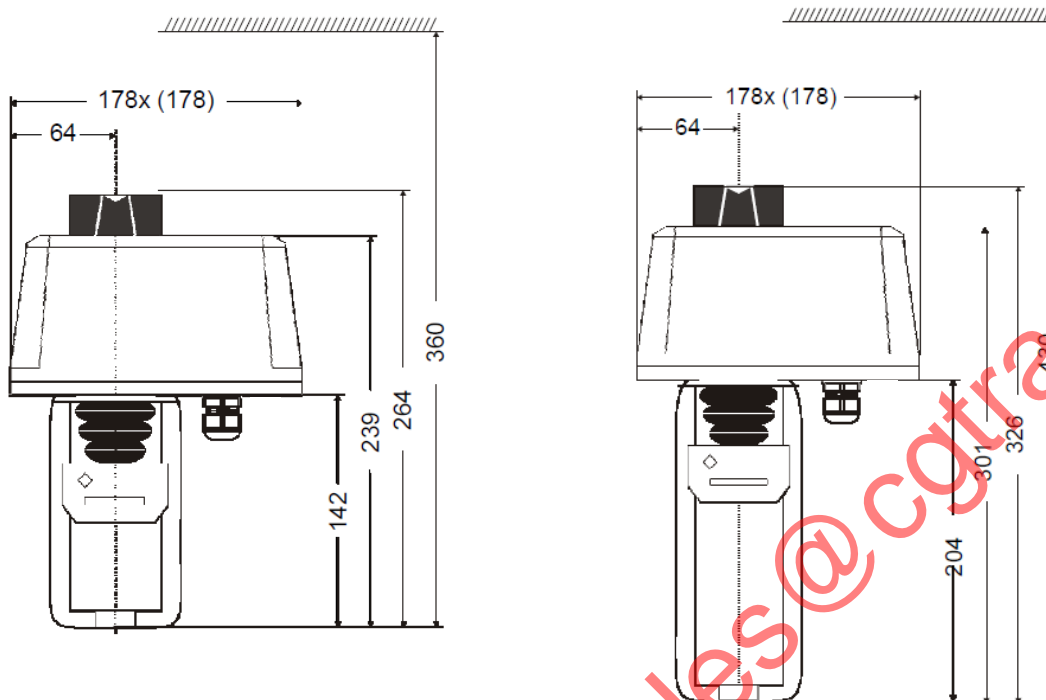

Note: all dimensions exclude high-temperature kit.

Fig. 2. ML7421A (Left) and ML7421B (Right)

Wiring

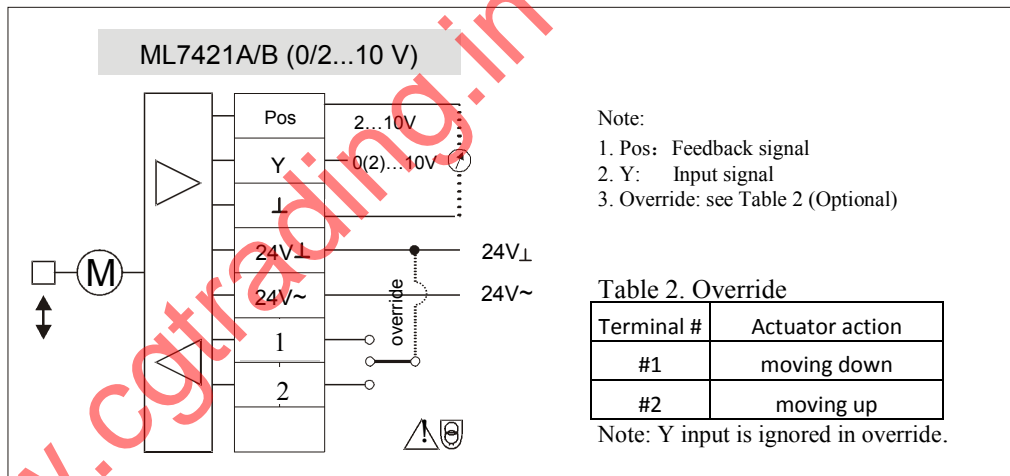

Honeywell

Honeywell ECC. (Tianjin) Co. Ltd.

Address: 158, TEDA, Tianjin, PRC. 300457

Phone: +86-22-66287000

Fax: +86-22-25325214

All information subject to change without prior notification!