

Spring return actuator with emergency function for adjusting air dampers in ventilation and air conditioning systems in buildings

- For air dampers up to approx. 2 m²
- Torque 10 Nm
- Nominal voltage
AC 24 ... 240 V / DC 24 ... 125 V
- Control: Open-close
- Two integrated auxiliary switches



Technical data

Electrical data	Nominal voltage	AC 24 ... 240 V, 50/60 Hz / DC 24 ... 125 V	
	Nominal voltage range	AC 19,2 ... 264 V / DC 21,6 ... 137,5 V	
	Power consumption	In operation	6 W @ nominal torque
		At rest	2,5 W
		For wire sizing	9,5 VA
	Auxiliary switch	2 x SPDT, 1 mA ... 3 (0.5) A, AC 250 V <input type="checkbox"/> (1 x fix 10% / 1 x adjustable 10 ... 90%)	
Connection	Motor	Cable 1 m, 2 x 0.75 mm ²	
	Auxiliary switch	Cable 1 m, 6 x 0.75 mm ²	
Functional data	Torque	Motor	Min. 10 Nm @ nominal voltage
		Spring return	Min. 10 Nm
	Direction of rotation	Can be selected by mounting L / R	
	Manual override	With hand crank and interlocking switch	
	Angle of rotation	Max. 95°↔, can be limited with adjustable mechanical end stop	
	Running time	Motor	≤75 s (0 ... 10 Nm)
		Spring return	20 s @ -20 ... 50°C / max. 60 s @ -30°C
	Sound power level	Motor	≤45 dB (A)
		Spring return	≤62 dB (A)
	Service life	Min. 60,000 emergency positions	
	Position indication	Mechanical	
	Safety	Protection class	II Totally insulated <input type="checkbox"/>
Degree of protection		IP54	
		NEMA2, UL Enclosure Type 2	
EMC		CE according to 2004/108/EC	
Low-voltage directive		CE according to 2006/95/EC	
Certification		Certified to IEC/EN 60730-1 and IEC/EN 60730-2-14 cULus according to UL 60730-1A and UL 60730-2-14 and CAN/CSA E60730-1:02	
Mode of operation		Type 1.AA.B	
Rated impulse voltage		Actuator	4 kV
		Auxiliary switch	2.5 kV
Control pollution degree		3	
Ambient temperature	-30 ... +50°C		
Non-operating temperature	-40 ... +80°C		
Ambient humidity	95% r.h., non-condensating		
Maintenance	Maintenance-free		
Dimensions / Weight	Dimensions	See «Dimensions» on page 3	
	Weight	Approx. 2.2 kg	

Safety notes



- The actuator is not allowed to be used outside the specified field of application, especially in aircraft or in any other airborne means of transport.
- **Caution: Power supply voltage possible!**
- It may only be installed by suitably trained personnel. Any legal regulations or regulations issued by authorities must be observed during assembly.
- The device may only be opened at the manufacturer's site. It does not contain any parts that can be replaced or repaired by the user.
- The cables must not be removed from the device.
- When calculating the required torque, the specifications supplied by the damper manufacturers (cross-section, design, installation site), and the air flow conditions must be observed.
- The integrated switches of this actuator have to be connected either to Power supply voltage or safety extra low voltage. The combination Power supply voltage / safety extra low voltage is not allowed.
- The device contains electrical and electronic components and is not allowed to be disposed of as household refuse. All locally valid regulations and requirements must be observed.

Product features

Mode of operation	The actuator is equipped with a universal power module and can process supply voltages from AC 24 ... 240 V plus DC 24 ... 125 V. The actuator moves the damper to the operating position at the same time as tensioning the return spring. The damper is turned back to the emergency position by spring force if the supply voltage is interrupted.
Simple direct mounting	Simple direct mounting on the damper spindle with a universal spindle clamp, supplied with an anti-rotation strap to prevent the actuator from rotating.
Manual override	Manual operation of the damper with the hand crank, locking in any position with the interlocking switch. Unlocking is manual or automatic by applying the operating voltage.
Adjustable angle of rotation	Adjustable angle of rotation with mechanical end stop.
High operational reliability	The actuator is overload-proof, requires no limit switches and automatically stops when the end stop is reached.
Flexible signalization	The actuator has one auxiliary switch with a fixed setting and one adjustable auxiliary switch. They permit a 10% or 10 ... 90% angle of rotation to be signalled.

Electrical installation

Wiring diagram

Notes

- Caution: Power supply voltage possible!
- Parallel connection of other actuators possible. Note the performance data.

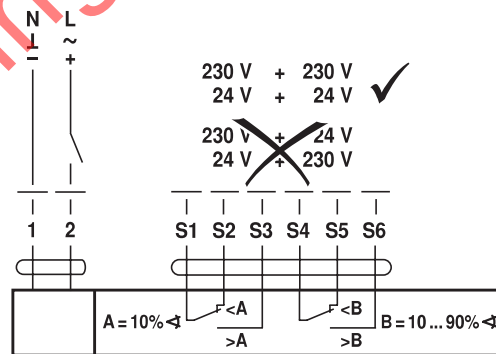

Accessories

	Description	Data sheet
Electrical accessories	Auxiliary switch unit S2A-F *	T2 - S2A-F
	Feedback potentiometer unit P200A-F *	T2 - P200A-F
Mechanical accessories	Various accessories	



* further versions on request

Dimensions [mm]

Dimensional drawings



Variant 1a:

3/4"-spindle clamp (with insertion part) EU Standard

Damper spindle	Length	● I	■ I	◆ I
	≥85	10 ... 22	10	14 ... 25.4
	≥15			



Variant 1b:

1"-spindle clamp (without insertion part) EU Standard

Damper spindle	Length	● I	■ I
	≥85	19 ... 25.4	12 ... 18
	≥15	(26.7)	

Variant 2:

1/2"-spindle clamp (optional via configuration)

Damper spindle	Length	● I	◆ I
	≥85	10 ... 19	14 ... 20
	≥15		

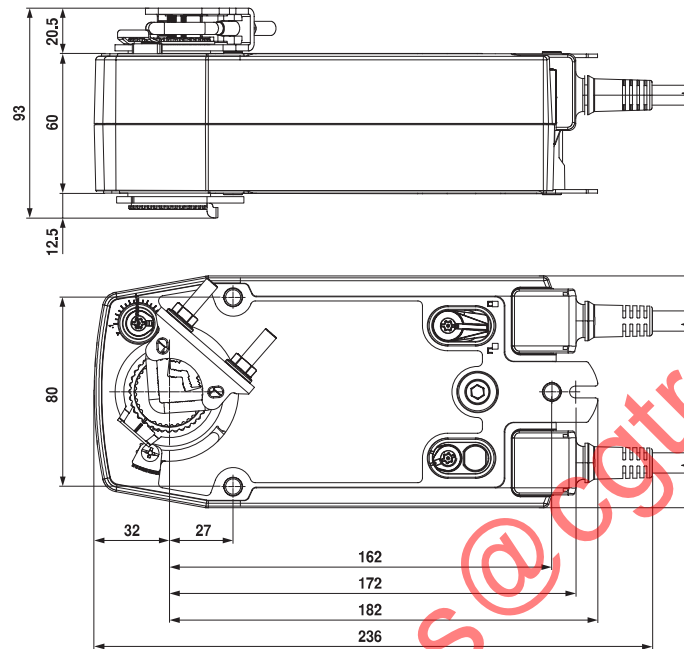

www.cgtrading.in E: sales@cgtrading.in

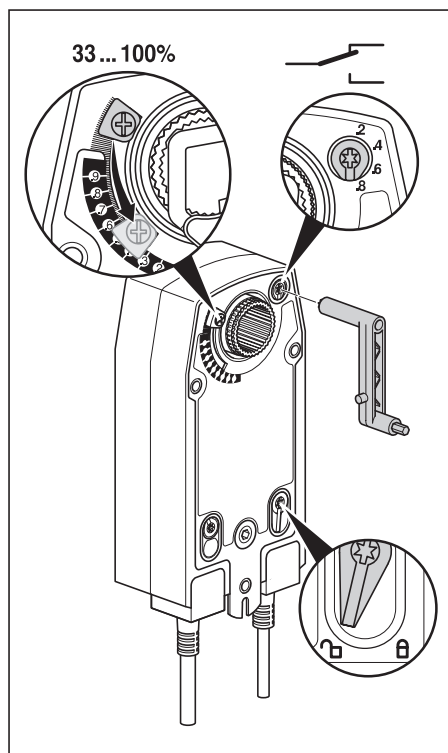
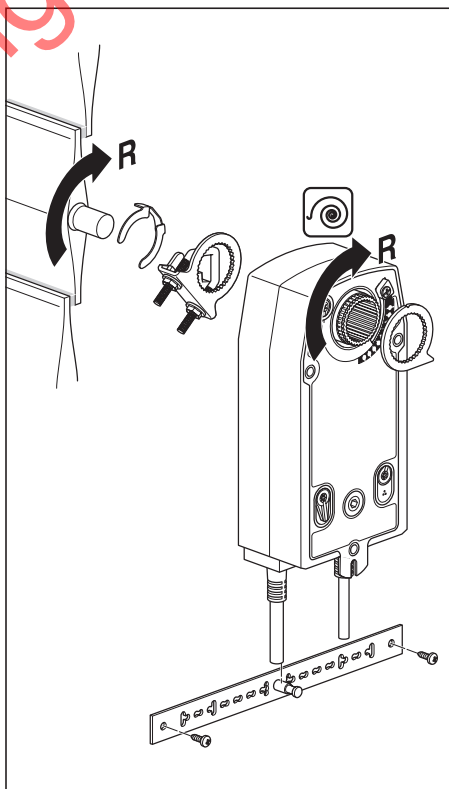
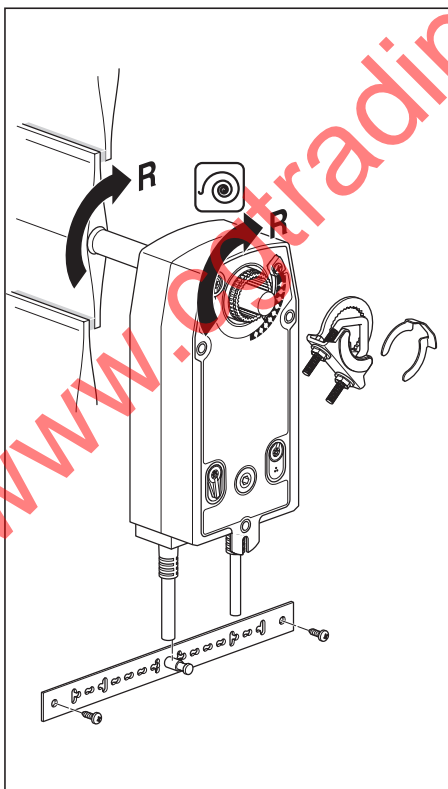
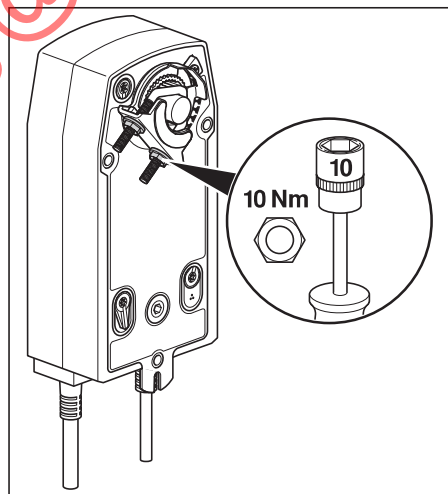
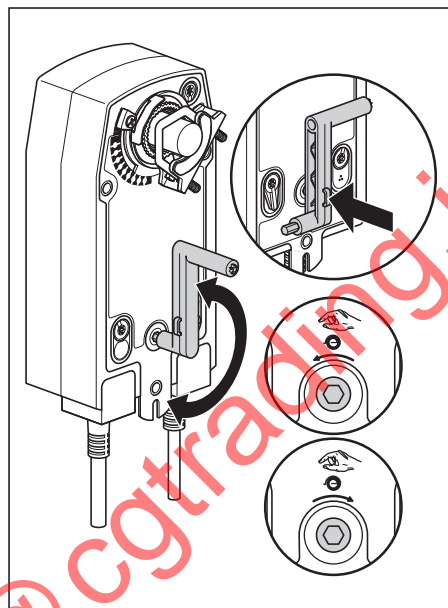
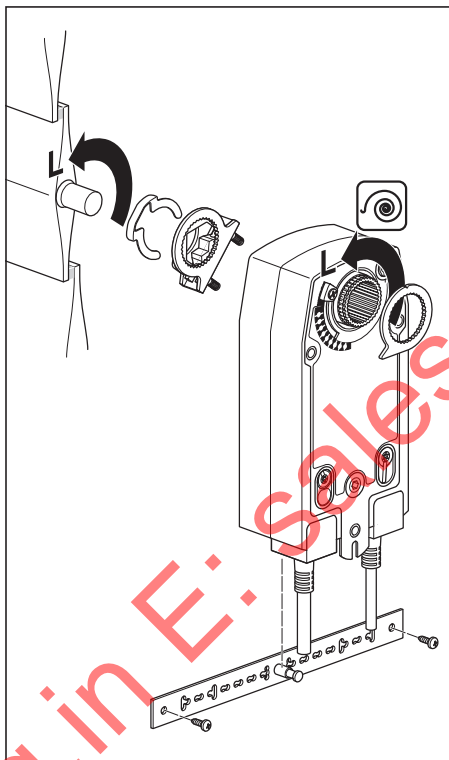
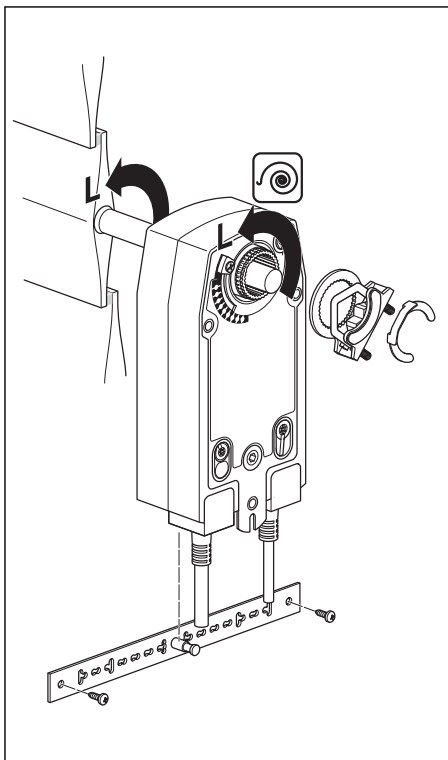
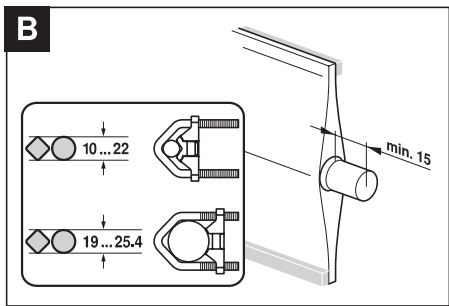
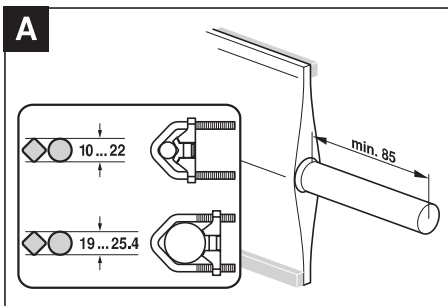

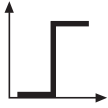

AC 24 V / DC 24 V

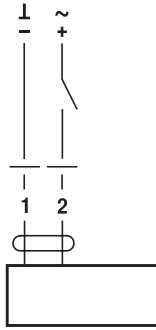

NF24A
SF24A

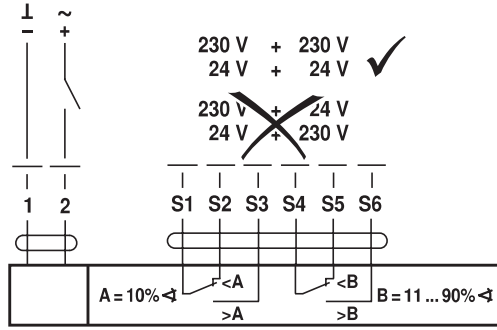

NF24A-S2
SF24A-S2

AC 230 V ⚠

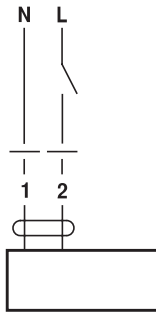

NF230A
SF230A

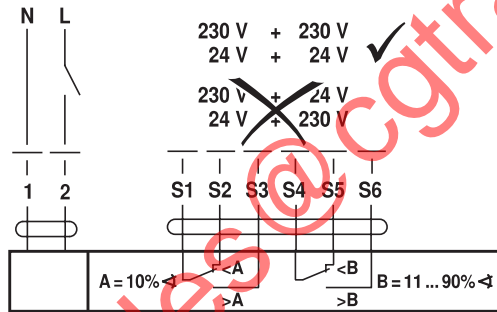

NF230A-S2
SF230A-S2

AC 24 ... 240 V / DC 24 ... 125 V ⚠

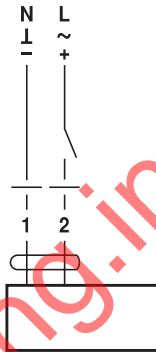

NFA
SFA

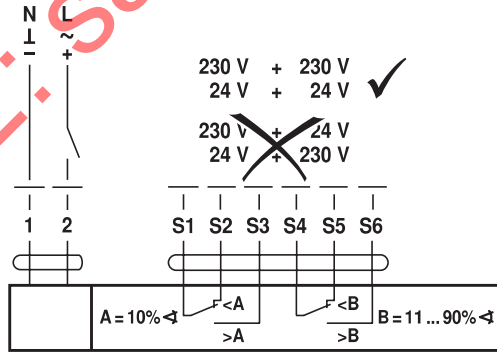

NFA-S2
SFA-S2

www.cgtrading.in E-Sales@cgtrading.in