



VPP46..



VPI46..



VPP46..Q, with pressure test points P/T



VPI46..Q, with pressure test points P/T

ACVATIX™

Combi valves, PN 25

VPP46..
VPP46..Q
VPI46..
VPI46..Q

for rooms, zones, ventilation and air-conditioning systems

- With integrated differential pressure controller
- DN 10...DN32: Valve body made of dezincification resistant hot-pressed brass (DZR)
- DN 40...DN 50: Housing made of spheroidal graphite iron
- Volumetric flow 30... 11500 l/h,
- Differential pressure range 15...600 kPa
- Internally threaded Rp conforming to ISO 7-1
- Externally threaded G conforming to ISO 228-1
- Version with pressure test points for Δp measurement (optional)
- Can be equipped with electro thermal or electromotive actuators
 - SSA.. (3-position or DC 0...10 V)
 - STA..3./STP..3.. (2-position or PDM)
 - STA63../STP63.. (DC 0...10 V)
 - SAY..1P03 (3-position or DC 0...10 V)

Use

- In ventilation and air conditioning plants for control on the water side and automatic hydraulic balancing of terminal units, such as fan coils, induction units, and in heat exchangers for heating or cooling
- In heating zones like self-contained heating systems, apartments, individual rooms, etc.
- For closed circuits

Type summary

Product no.	Stock	DN	H ₁₀₀ [mm]	Connections [inch]	Test points	V̇ _{min} [l/h]	V̇ ₁₀₀ [l/h]	STA..3.. / STP..3.. ¹⁾		SSA..				
								Δp _{min} [kPa]	Δp _{max} [kPa]	Δp _{min} [kPa]	Δp _{max} [kPa]			
VPP46.10L0.2	S55264-V101	10	2,5	G ½	-	30	200	Refer to page 8	600	Refer to page 8	600			
VPP46.15L0.2	S55264-V102	15		G ¾		30	200		600		600			
VPP46.15L0.6	S55264-V103					100	575		600		600			
VPP46.20F1.4	S55264-V104	20	4,5	G 1		200	1190		600		-			
			5			220	1330		-		600			
VPP46.25F1.8	S55264-V121	25	4,5	G 1 1/4		238	1530		600		-			
			5,5			280	1800		-		600			
VPP46.32F4	S55264-V122	32	4,5	G 11/2		468	3400		600		-			
			5,5			550	4001		-		600			
VPP46.10L0.2Q	S55264-V105	10	2,5	G ½		with pressure test points P/T	30		200		Refer to page 8	600	Refer to page 8	600
VPP46.15L0.2Q	S55264-V106	15		G ¾			30		200			600		600
VPP46.15L0.6Q	S55264-V107						100		575			600		600
VPP46.20F1.4Q	S55264-V108	20	4,5	G 1	200		1190	600	-					
			5		220		1330	-	600					
VPP46.25F1.8Q	S55264-V123	25	4,5	G 1 1/4	238		1530	600	-					
			5,5		280		1800	-	600					
VPP46.32F4Q	S55264-V124	32	4,5	G 11/2	468		3400	600	-					
			5,5		550		4001	-	600					
VPI46.15L0.2	S55264-V109	15	2,5	Rp ½	-		30	200	Refer to page 8	600		Refer to page 8		600
VPI46.15L0.6	S55264-V110			Rp ¾			100	575		600				600
VPI46.20F1.4	S55264-V111	20	4,5				Rp 1	200		1190				600
			5	220		1330		-		600				
VPI46.25F1.8	S55264-V125	25	4,5	Rp 1		238	1530	600		-				
			5,5			280	1800	-		600				
VPI46.32F4	S55264-V126	32	4,5	Rp 11/4		468	3400	600		-				
			5,5			550	4001	-		600				
VPI46.15L0.2Q	S55264-V112	15	2,5	Rp ½		with pressure test points P/T	30	200		Refer to page 8	600		Refer to page 8	600
VPI46.15L0.6Q	S55264-V113			Rp ¾			100	575			600			600
VPI46.20F1.4Q	S55264-V114	20	4,5				Rp 1	200			1190			600
			5	220				1330			-			600
VPI46.25F1.8Q	S55264-V127	25	4,5	Rp 1	238		1530	600	-					
			5,5		280		1800	-	600					
VPI46.32F4Q	S55264-V128	32	4,5	Rp 11/4	468		3400	600	-					
			5,5		550		4001	-	600					

¹⁾ STP..3.. may only be used together with VPP46 DN 10 and DN 15 and VPI46 DN 15.

Product no.	Stock no.	DN	H ₁₀₀	Connections		Test points	V̇ _{min} [l/h]	V̇ ₁₀₀ [l/h]	SAY..P	
			[mm]	[Inch]	internally threaded				with pressure test points P/T	Δp _{min} [kPa]
VPI46.40F9.5Q	S55264-V129	40	15	Rp11/2	internally threaded	with pressure test points P/T	1370	9500	25	600
VPI46.50F12Q	S55264-V130	50	15	Rp2			1400	11500	36	600

DN = nominal size

H₁₀₀ = nominal stroke

V̇₁₀₀ = volumetric flow through fully open valve (H₁₀₀)

V̇_{min} = smallest pre-settable volumetric flow through fully open valve (H₁₀₀)

Δp_{max} = maximum permissible differential pressure across the valves control path, valid for the entire actuating range of the motorized valve

Δp_{min} = minimum differential pressure required across the valve's control path, so that the difference pressure regulator works reliably

Fittings

Product no.	Stock no.	Description
ALG..2	ALG..2	Set of 2 fittings with threaded connections for 2-port valves, consisting of 2 union nuts, 2 discs and 2 flat seals. ALG..2B are brass fittings, for media temperatures up to 100 °C.
ALG..2B	S55846-Z1..	

Ordering

Example

Product no.	Stock no.	Designation
VPP46.15L0.2	S55264-V102	Combi valve, PN 25, externally threaded
SSA61	SSA61	Actuator

Delivery PICV valves, actuators and accessories are packed and supplied separately.

Revision numbers See page 18

Equipment combinations DN 15- 32

Actuators	Operating voltage	signal	Positioning time		force	Actuators (no power) ¹⁾	Spring return	Stroke	Connecting cable	Data sheet			
			2.5 mm										
SSA31	AC 230 V	3-position	150 s	60 s/mm	100 N		-	2.5 mm 5 mm	1.5 m	N4893			
SSA81	AC 24 V												
SSA61	AC/DC 24 V										DC 0...10 V	75 s	30 s/mm
SSA61EP		DC 0...10 V	75 s	30 s/mm									
STA23..	AC 230 V	2-position, PDM	270 s	110 s/mm	100 N	NC	✓	2.5 mm max. 4.5 mm	see data sheet	N4884			
STA73..	AC/DC 24V												
STA63..	AC 24 V										DC 0...10 V	30 s	12 s/mm
STP23.. ²⁾	AC 230 V										2-position	210 s	80 s/mm
STP73.. ²⁾	AC/DC 24V										2-position, PDM	270 s	110 s/mm
STP63.. ²⁾	AC 24 V										DC 0...10 V	30 s	12 s/mm

¹⁾ NC = Normal Closed = VPP46../VPI46.. powerless closed

NO = Normal Open = VPP46../VPI46.. powerless open

The valve is fully opened without an actuator

²⁾ STP..3.. may only be used together with VPP46 DN 10 and DN 15 and VPI46 DN 15.

Equipment combinations DN 40- 50

Type	Article number	Stroke	Pos. force	Operating voltage	Positioning signal	Spring return	Spring return direction	Pos. time	LED	Manual adjustment	Auxiliary functions
SAY31P03	S55150-A132	15 mm	200 N	AC 230 V	3-position	-	-	30 s	-	Press and fix in place	¹⁾
SAY61P03	S55150-A133			AC/DC 24 V	DC 0...10 V DC 4...20 mA 0...1000 Ω				²⁾ ³⁾		
SAY81P03	S55150-A134				3-position				-		¹⁾

¹⁾ Optional accessories: Auxiliary switch ASC10.51

²⁾ Positioning feedback, forced control, characteristic curve changeover

³⁾ Optional accessories: Auxiliary switch ASC10.51, sequence control, control action changeover AZX61.1

Fittings

Combi valves		Set of fittings		
Externally threaded		Malleable cast iron	Brass	
Product no.	Stock no.	Type / Stock no.	Product no.	Stock no.
VPP46.10L0.2	S55264-V101	-	ALG132 ¹⁾	BPZ:ALG132
VPP46.15L0.2	S55264-V102	-	ALG142 ¹⁾	BPZ:ALG142
VPP46.15L0.6	S55264-V103	-	ALG142 ¹⁾	BPZ:ALG142
VPP46.20F1.4	S55264-V104	ALG152	ALG152B ²⁾	S55846-Z100
VPP46.25F1.8	S55264-V121	ALG202	ALG202B ²⁾	S55846-Z102
VPP46.32F4	S55264-V122	ALG252	ALG252B ²⁾	S55846-Z104
VPP46.10L0.2Q	S55264-V105	-	ALG132 ¹⁾	BPZ:ALG132
VPP46.15L0.2Q	S55264-V106	-	ALG142 ¹⁾	BPZ:ALG142
VPP46.15L0.6Q	S55264-V107	-	ALG142 ¹⁾	BPZ:ALG142
VPP46.20F1.4Q	S55264-V108	ALG152	ALG152B ²⁾	S55846-Z100
VPP46.25F1.8Q	S55264-V123	ALG202	ALG202B ²⁾	S55846-Z102
VPP46.32F4Q	S55264-V124	ALG252	ALG252B ²⁾	S55846-Z104

¹⁾ Connecting thread pipe side: Internally threaded

²⁾ Usable up to maximum medium temperature of 100 °C

Technical / mechanical design

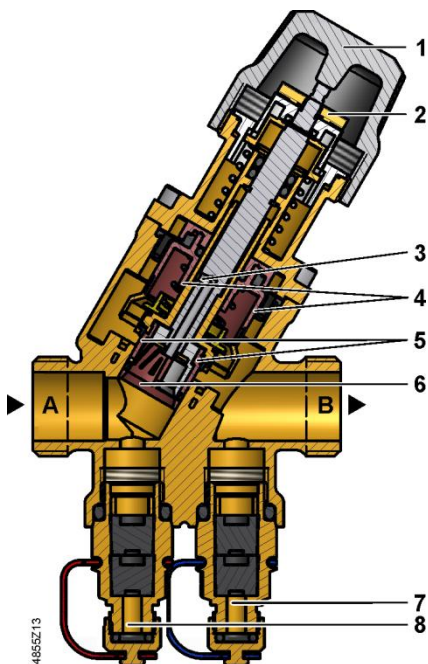

- 1 Manual control knob
 - 2 Ring with dial for presetting
 - 3 Aperture for differential pressure controller is linked with outlet port B
 - 4 Differential pressure controller
 - 5 Plug for presetting opening
 - 6 Flow control valve
 - 7 Pressure test point, blue ribbon, P-
 - 8 Pressure test point, red ribbon, P+
- A Inlet port A
B Outlet port B

Combi valves VP..46..Q (shown here) are additionally equipped with pressure test points P/T.

Functional principle

The medium entering the valve (inlet port A) passes through the variable presetting opening (5) which is connected to the ring with the dial (2) for presetting the desired maximum volumetric flow. Then, the medium flows through the flow control valve (6) with a linear characteristic and a stroke of 2.5 mm (DN 10...15) respectively 5 mm (DN 20).

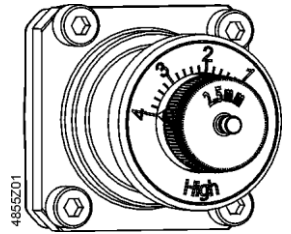

Ring with dial for presetting (2)

The actuator (not shown here) opens and accurately positions the control valve (6). Before leaving the Combi valve, the medium passes through a built-in mechanical differential pressure controller (4). This differential pressure controller is the heart of the Combi valve and ensures that the selected volumetric flow is maintained across the whole working range and independent of the inlet pressure p_1 . The Combi valves VP..46..Q are additionally equipped with two pressure test points (P+, P-), which allow measurement of the differential pressure across the Combi valve. For that purpose, the electronic manometer ALE10 can be used.

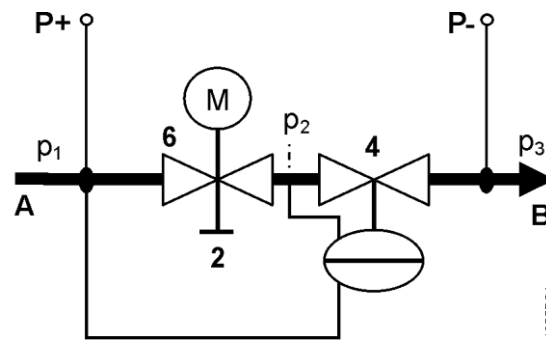

- A Inlet medium (inlet port)
- B Outlet medium (outlet port)
- 2 Ring with dial for presetting
- 4 Differential pressure controller maintains the pressure $p_1 - p_2$ constant across the flow control valve (6) and the presetting (2)
- 6 Control valve with mounted actuator

- P- = P/T port, pressure test point with blue ribbon (7)
- P+ = P/T port, pressure test point with red ribbon (8)
- p_1 = pressure at inlet of Combi valve
- p_2 = pressure at outlet of flow control valve
- p_3 = pressure at outlet of Combi valve

Manual control DN10-DN32

The manual control knob (1) is ready fitted to protect valve stem and pre-set mechanism and facilitates manual control of the Combi valve during commissioning.







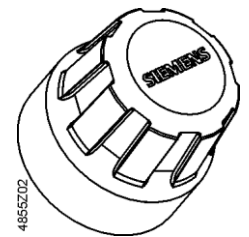

Factory setting:

The valve is open. To close the valve, turn the manual knob clockwise.

The valve must be open to purge the system.



Accessories

Product no.	Stock no.		Description
ALE10	ALE10		<p>Electronic manometer excluding measuring lines and measuring tips. Measuring range 0-700 kPa. A differential pressure of more than 1000 kPa will destroy the pressure sensor.</p> <p>For measuring the differential pressure between P+ and P- of the Combi valves (refer to diagram under "Functional principle" on page 3).</p> <p>Functions of the manometer:</p> <ul style="list-style-type: none"> • Start/stop • Automatic zero position • Backlit display • Display: Out → outside the measuring range • Holding function
ALE11	ALE11		<p>Measuring lines and straight measuring tips for use with Siemens Combi valves.</p> <p>Equipped with G 1/8" connection with 2 x 40 mm needles.</p>
ALP45	ALP45		<p>Spare nipples P/T port (set of 2) Set contains 1 piece each with a red and blue ribbon.</p> <p>Port: External threads G 1/8" to ISO 228 Connection to valve body: G 1/4" to ISO 228, inclusive O-ring</p>
ALP46	S55264-V115		<p>Blanking plug for P/T ports Connection to valve body: G 1/4" to ISO 228, inclusive O-ring</p>
ALP47	S55264-V116		<p>Drain ball valve inclusive O-ring Port: External threads G 1/2" to ISO 228 Connection to valve body: G 1/4" to ISO 228, inclusive O-ring</p>
ALP48	S55264-V117		<p>Combined P/T port and drain ball valve with red ribbon Port: External threads G 1/8" to ISO 228 Connection to valve body: G 1/4" to ISO 228, inclusive O-ring</p>
ALP49	S55264-V118		<p>Long P/T ports (set of 2 pieces) Set contains 1 piece each with a red and blue ribbon.</p> <p>Port: External threads G 1/8" to ISO 228 Connection to valve body: G 1/4" to ISO 228, inclusive O-ring</p>
ALP50	S55264-V119		<p>Spare black valve protection cap</p>

Engineering example

Basis of calculation

1. Determine energy demand Q [kW]
2. Determine temperature differential ΔT [K]
3. Calculate volumetric flow
$$\dot{V} = \frac{Q[\text{kW}] \cdot 1000}{1.163 \cdot \Delta T[\text{K}]} \left[\frac{\text{l}}{\text{h}} \right]$$
4. Select suitable Combi valve
 - pipe connections (internally or externally threaded)
 - with or without P/T ports
5. Determine dial setting using volumetric flow/dial presetting table, see the following page

Example

1. Given is a heat exchanger with $Q = 1.9 \text{ kW}$
2. Temperature differential (supply - return) $\Delta T = 6 \text{ K}$
3. Volumetric flow

$$\dot{V} = \frac{1.9 \text{ kW} \cdot 1000}{1.163 \cdot 6 \text{ K}} = 272,28 \text{ l/h}$$

Hint: You can also determine the volumetric flow using the valve slide rule.

4. The valve shall have connections with external threads to ISO 228-1 and size DN 15.
5. Combi valve selection:

Ideally, Combi valves should be selected such that they operate at about 80% of their maximum flow, enabling them to deliver spare capacity, if required.

VPP46.15L0.6 (externally threaded connections, no pressure test points P/T, nominal volumetric flow 600 l/h)
6. Determine dial setting using volumetric flow/dial presetting table below:

Volumetric flow	270 l/h
Dial setting	1.8

**Volumetric flow/dial
presetting**

Tables to determine the dial setting for a desired volumetric flow.

Dp min [kPa] based on volumetric flow; interpolate missing values.

- Presetting range linear to VDI/VDE 2173
- Presetting range linear
- Presetting range not permitted

VPP46.10L0.2, VPP46.10L0.2Q, VPP46.15L0.2, VPP46.15L0.2Q, VPI46.15L0.2, VPI46.15L0.2Q																			200 l/h nominal			
[l/h]				30	35	40	50	60	70	80	90	100	110	120	130	140	150	160	170	180	190	200
Scale	Min.	0.2	0.4	0.5	0.6	0.8	1	1.2	1.4	1.6	1.8	2	2.2	2.4	2.6	2.8	3	3.2	3.4	3.6	3.8	Max.
kPa				14.3			14.5					14.9					15.4					15.8

VPP46.15L0.6, VPP46.15L0.6Q, VPI46.15L0.6, VPI46.15L0.6Q																			600 l/h nominal			
[l/h]				100	115	130	160	180	210	240	270	300	320	350	380	410	440	460	490	520	550	575
Scale	Min.	0.2	0.4	0.5	0.6	0.8	1	1.2	1.4	1.6	1.8	2	2.2	2.4	2.6	2.8	3	3.2	3.4	3.6	3.8	Max.
kPa				14.9			15.5					16.6					17.6					18.5

VPP46.20F1.4, VPP46.20F1.4 Q with STA/STP, VPI46.20F1.4, VPI46.20F1.4Q with STA./STP.																			1200 l/h nominal			
[l/h]					200	260	310	380	430	490	550	610	660	730	780	840	900	960	1010	1070	1130	1190
Scale	Min.	0.2	0.4	0.5	0.6	0.8	1	1.2	1.4	1.6	1.8	2	2.2	2.4	2.6	2.8	3	3.2	3.4	3.6	3.8	Max.
kPa					16		17					19.2					20.7					21.6

VPP46.20F1.4, VPP46.20F1.4Q, VPI46.20F1.4, VPI46.20F1.4Q																			1400 l/h nominal			
[l/h]					220	290	350	420	480	550	610	680	740	810	870	940	1000	1070	1130	1200	1260	1330
Scale	Min.	0.2	0.4	0.5	0.6	0.8	1	1.2	1.4	1.6	1.8	2	2.2	2.4	2.6	2.8	3	3.2	3.4	3.6	3.8	Max.
kPa					16		17			18.4		19.2			20.2		20.7					21.6

VPP46.25F1.8, VPP46.25F1.8Q, VPI46.25F1.8, VPI46.25F1.8Q with STA..																			1530 l/h nominal			
[l/h]					238	303	366	427	488	550	614	680	749	822	898	978	1063	1150	1241	1335	1432	1530
Scale	Min.	0.2	0.4	0.5	0.6	0.8	1	1.2	1.4	1.6	1.8	2	2.2	2.4	2.6	2.8	3	3.2	3.4	3.6	3.8	Max.
kPa					15		16					18					24					39

VPP46.25F1.8, VPP46.25F1.8Q, VPI46.25F1.8, VPI46.25F1.8Q																			1800 l/h nominal			
[l/h]					280	356	430	502	574	647	722	800	881	967	1057	1151	1250	1353	1460	1571	1685	1800
Scale	Min.	0.2	0.4	0.5	0.6	0.8	1	1.2	1.4	1.6	1.8	2	2.2	2.4	2.6	2.8	3	3.2	3.4	3.6	3.8	Max.
kPa					15		16					18					24					39

VPP46.32F4, VPP46.32F4Q, VPI46.32F4, VPI46.32F4Q with STA..																			3400 l/h nominal			
[l/h]					468	680	770	940	1120	1290	1460	1640	1810	1980	2150	2330	2500	2670	2850	3020	3190	3400
Scale	Min.	0.2	0.4	0.5	0.6	0.8	1	1.2	1.4	1.6	1.8	2	2.2	2.4	2.6	2.8	3	3.2	3.4	3.6	3.8	Max.
kPa					18			18.2		18.5		18.9	19.2	19.6	20.1	20.7	21.4	22.3	23.4	24.6	26	28

VPP46.32F4, VPP46.32F4Q, VPI46.32F4, VPI46.32F4Q																			4000 l/h nominal			
[l/h]					550	800	910	1110	1320	1520	1720	1930	2130	2330	2530	2740	2940	3140	3350	3550	3750	4001
Scale	Min.	0.2	0.4	0.5	0.6	0.8	1	1.2	1.4	1.6	1.8	2	2.2	2.4	2.6	2.8	3	3.2	3.4	3.6	3.8	Max.
kPa					18			18.2		18.5		18.9	19.2	19.6	20.1	20.7	21.4	22.3	23.4	24.6	26	28

VPI46.40F9.5Q																			9500 l/h nominal			
[l/h]					1370	1600	1950	2250	2650	3000	3400	3800	4250	4750	5250	5800	6350	6950	7550	8200	8800	9500
Scale	Min.	0.2	0.4	0.5	0.6	0.8	1	1.2	1.4	1.6	1.8	2	2.2	2.4	2.6	2.8	3	3.2	3.4	3.6	3.8	Max.
kPa					10						10		11	12	13	15	16	18	20	22	24	25

VPI46.50F12Q																			11500 l/h nominal			
[l/h]					1400	1650	2000	2350	2700	3150	3550	4050	4600	5150	5800	6500	7300	8150	9000	9800	10600	11500
Scale	Min.	0.2	0.4	0.5	0.6	0.8	1	1.2	1.4	1.6	1.8	2	2.2	2.4	2.6	2.8	3	3.2	3.4	3.6	3.8	Max.
kPa					10				11		12	13	14	15	17	19	21	24	27	30	33	36

Engineering notes

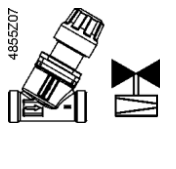
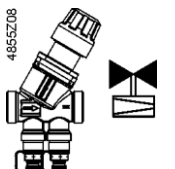
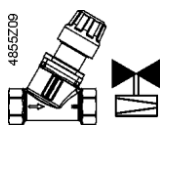
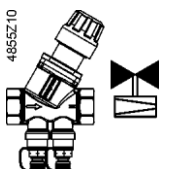
Valve	Symbols / Direction of flow		Flow in control mode	Valve stem	
	VP..46..	VP..46..Q		retracts	extends
Combi valve VPP46..			variable	closes	opens
Combi valve VPI46..			variable	closes	opens



The direction of flow indicated (arrow on the valve body) is mandatory!

The valves should preferably be mounted in the return pipe where temperatures are lower and where the sealing gland is less affected by strain.

Symbols

Symbol used in catalogs and application descriptions	Symbol used in diagrams
	There are no standard symbols for Combi valves in diagrams.

Recommendation

A strainer or dirt trap should be fitted upstream of the valve to enhance reliability. Remove dirt, welding beads etc. from valves and pipes. Do not insulate the actuator bracket, as air circulation must be ensured!

Mounting notes

Combi valve and actuator can be straightforwardly assembled on site. Special tools or adjustments are not required.

Prior to mounting the actuator, the required volumetric flow must be set.

The valve is supplied complete with Mounting Instructions (74 319 0649 0 b).

Mounting positions

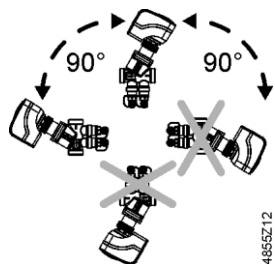

Thermal actuators STA..., STP.. may be installed in any position.

Actuators SSA..., SAY.. must be installed horizontally up to 90° and not hanging.

Installation notes

Presetting DN10-32:

Prior to mounting the actuator, the presetting is to be made as follows:

1. Remove control knob from Combi valve.

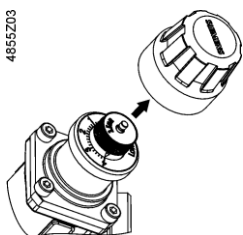

2. Loosen knurled nut.

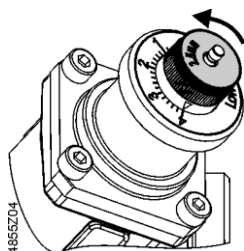

3. Adjust the desired dial setting with the white knob.

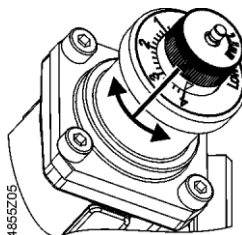

4. Retighten knurled nut by hand.

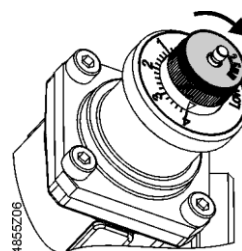

Presetting DN40-50:

1. Loosen spindle head

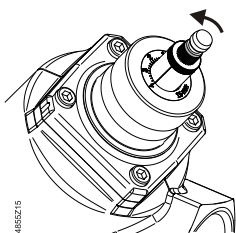

2. Adjust the desired dial setting with the white knob.

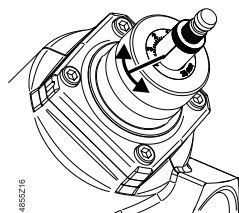

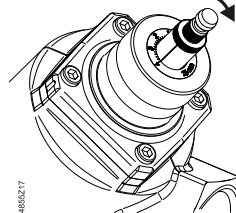

3. Retighten spindle head - by hand only

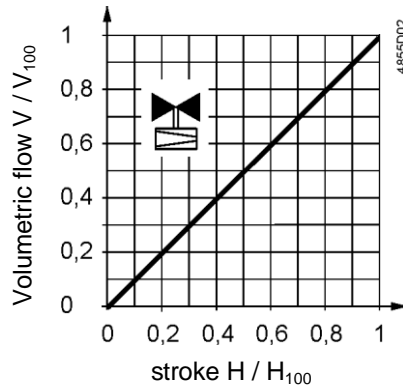

Valve characteristic
VP..46.., VP..46..Q



Commissioning notes

-  **The valves must be commissioned with the manual control knob or actuator correctly fitted. Strong pressure impacts can damage closed Combi valves.**
-  **The Combi valves have to be open when flushing or pressure testing the system. Flush only in correct flow direction. Strong pressure impacts can damage closed Combi valves.**
-  **Differential pressure Δp_{\max} across the valve's control path is not allowed to exceed 600 kPa.**

Manual control

When turning the manual control knob in counter-clockwise direction or manually operating the actuator, the valve opens. The actuator closes the valve. The valves are supplied fully open. The manual knob is not designed for permanent manual operation.

Maintenance notes

-  The V..P46.. PICV valves are maintenance-free without cartridge. Valve plug, stem, presetting, diaphragm etc. may not be disassembled. When performing service work on the valve and / or actuator:
 - Switch off the pump and disconnect power supply.
 - Close the shut-off valves in the piping network.
 - Fully reduce pressure in the piping network and allow the pipes to cool down completely.

Remove the electrical connections only if necessary.

Sealing gland

The stem sealing gland cannot be exchanged. Should leakage occur, the whole valve must be replaced.

Disposal

Do not dispose of the device as household waste.

 **Warning**

Due to the tensioned spring return, valve disassembly may result in flying parts causing possible injury.

Only authorized staff may disassemble valves with tensioned spring return!

Disposal

- Special handling of individual components may be mandated by law or make ecological sense.
- Observe all local and currently applicable laws and regulations.

Warranty

Application-related technical data are guaranteed only when the valves are used in connection with the Siemens actuators listed under "Equipment combinations" on page 3. When used with actuators of other manufacture, any warranty by Siemens becomes void.

Technical data

Functional data	PN class	PN 25 as per EN 1333
	Permissible operating pressure	2.500 kPa (25 bar) as per ISO 7628 / EN 1333
	Max. differential pressure	600 kPa
	Min. differential pressure	See tables volumetric flow/dial presetting
	Valve characteristic	Linear as per VDI/VDE 2173
	Leakage rate in general	Class IV (0...0.01% of volumetric flow V_{100}) to EN 1349
	DN 25- 32 with STA..3..	Class III (0...0,1% of volumetric flow V_{100}) per EN 1349
	Average flow accuracy	+/-10% from ΔP_{min} - to $2.5 \times \Delta P_{min}$ +/- 5% from $2.5 \times \Delta P_{min}$ – to 600kPa
	Permissible media	Low-temperature hot water, chilled water, water with antifreeze Recommendation: Water treatment to VDI 2035
	Medium temperature:	
	Valve with actuator	1...120 °C
	Permissible ambient temperature	1...50 °C
	Nominal stroke	DN 10...DN 15 2.5 mm DN 20 5 mm DN25- 32 5.5 mm DN40- 50 15 mm
	Materials	Valve body, port, seat, sealing gland and test points
Valve body DN40- 50		Nodular cast iron
Stem, spring		Stainless steel
Presetting element		PTFE, PPO, POM C and ABS
Regulator		PPS
Seals	EPDM 281 (O-ring)	
Dimensions / weight	Dimensions	Refer to "Dimensions" on page 15
	Threaded connections	VPP46.. G to ISO 228-1 (externally threaded) VPI46.. Rp to ISO 7-1 (internally threaded)
	Actuator connection	DN10- 32 M30 x 1.5 mm DN40- 50 Siemens large stroke connector
	Pressure test points (P/T-ports)	G 1/4" (connection valve body) 2 mm x 40 mm (needles)
	Weight	Refer to "Dimensions" on page 15

Standards, directives and approvals	Pressure Equipment Directive	PED 2014/68/EU
	Pressure-carrying accessories	Scope: Article 1, section 1 Definitions: Article 2, section 5
	Fluid group 2	Without CE-marking as per article 4, section 3 (sound engineering practice) ¹⁾
	DN 10...40 DN 50	Category I, Modul A, with CE-marking as per article 14, section 2
	EU conformity (CE)	DN 50 A5W00022837, CE1T4855xx ²⁾
	EAC conformity	Eurasia conformity
Environmental compatibility	The product environmental declaration CE1E4855en ²⁾ contains data on environmentally compatible product design and assessments (RoHS compliance, materials composition, packaging, environmental benefit, disposal).	

¹⁾ Valves where PS x DN < 1000, do not require special testing and cannot carry the CE label.

²⁾ Documents are available at <http://www.siemens.com/bt/download>

Application examples

Combi valves in HVAC systems combined with variable speed pumps provide even higher energy efficiency. When sizing the pump, it must be made certain that the most critical branch or consumer in the system – usually the remotest from the pump – gets enough pressure (pump head). Thus, it is recommended to use a variable speed pump in constant-pressure mode with end-point feedback, to maintain a minimum differential pressure across the critical valve.

Residential buildings

Residential buildings with for example self-contained flat heating systems:

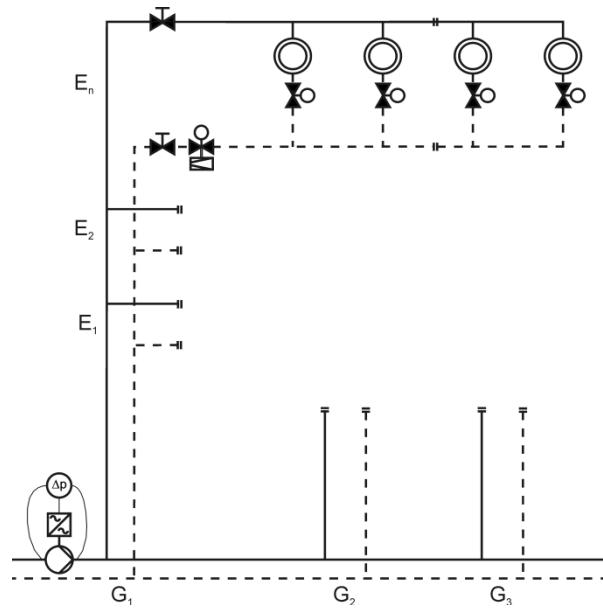

E = Floor
G = Group or zone

Non-residential buildings

Commercial buildings with for example Fan Coil Units or heat exchangers for heating or cooling:

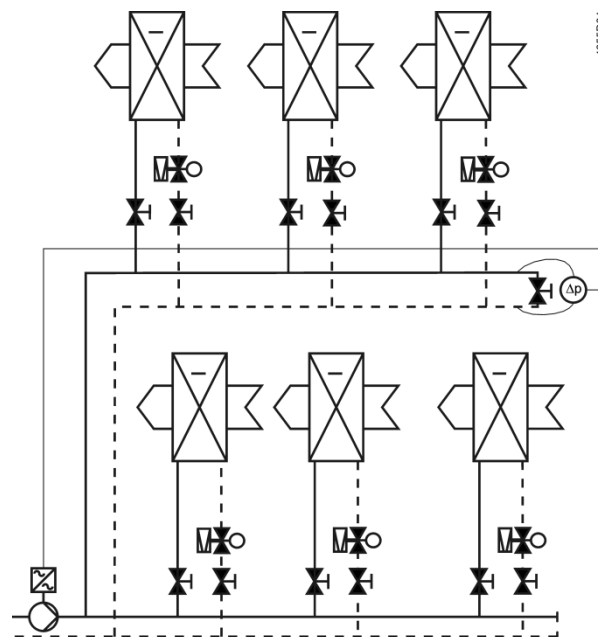

Dimensions

VPP46..

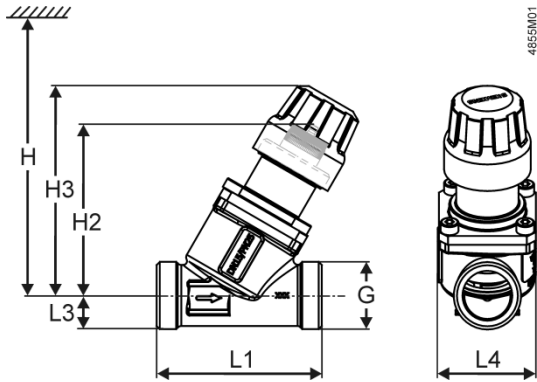

VPP46..Q

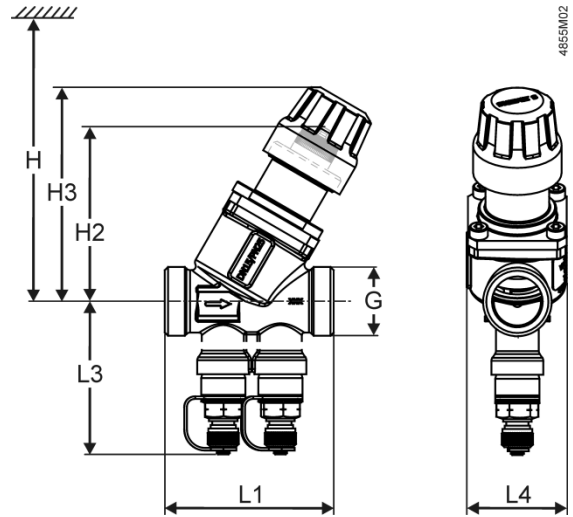

Valves	DN	G [inch]	L1 [mm]	L3 [mm]	L4 [mm]	H2 [mm]	H3 [mm]	H ¹⁾		Weight [kg]
								SSA.. [mm]	STA..3.. STP..3.. [mm]	
VPP46.10L0.2	10	½	65	10,5	38	68,5	83,5	170	160	0,329
VPP46.15L0.2	15	¾		13,2		67,3	82,2			0,348
VPP46.15L0.6			65	13,2		67,3	82,2			0,348
VPP46.20F1.4	20	1	70	13,6		67,5	82,5			0,386
VPP46.25F1.8	25	1-1/4	78	22		70	85			0,512
VPP46.32F4	32	1-1/2	104	26	63	85	100	185	175	1,235
VPP46.10L0.2Q	10	½	65	54,8	38	68,5	83,5	170	160	0,429
VPP46.15L0.2Q	15	¾		55,5		67,3	82,2			0,429
VPP46.15L0.6Q			55,5	67,3		82,2	0,429			
VPP46.20F1.4Q	20	1	70	57,3		67,5	82,5			0,486
VPP46.25F1.8Q	25	1-1/4	78	59		70	85			0,617
VPP46.32F4Q	32	1-1/2	104	68	63	85	100	185	175	1,344

¹⁾ Total height including actuator

Sets of threaded fittings with flat seal			
ALG...2: set of 2 threaded fittings	ALG132 ALG142	pipe side with external R threads	
	ALG152 ALG152B ALG202 ALG202B ALG252 ALG252B	pipe side with internal Rp threads	

Type ALG..	for valve type	DN	G	R	Rp	L	T
Malleable cast iron	Brass ¹⁾		[Inch]	[Inch]	[Inch]	[mm]	[mm]
	ALG132	VPP46.10..	10	G ½	R ¾	≈ 24	≈ 9
	ALG142	VPP46.15..	15	G ¾	R 1½	≈ 29.5	≈ 12
ALG152	ALG152B	VPP46.20..	20	G 1	Rp ½	≈ 23	≈ 13
ALG202	ALG202B	VPP46.25..	25	G 1 1/4	Rp ¾		
ALG252	ALG252B	VPP46.32..	32	G 1 1/2	Rp 1		

¹⁾ Maximum medium temperature 100 °C

- On valve side: cylindrical thread to ISO 228-1, on pipe side: with cylindrical thread to ISO 7-1

VPI46..

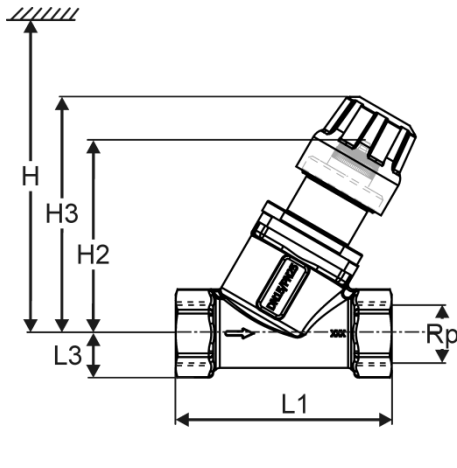

4855M03

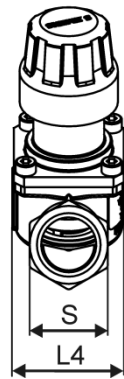

VPI46..Q

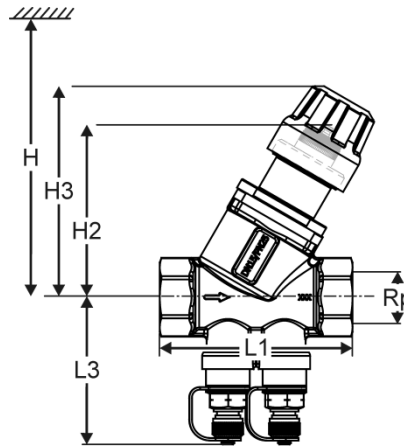

4855M04



Valves	DN	Rp	S	L1	L3	L4	H2	H3	H ¹⁾			Weight
									SSA..	STA..3.. STP..3..	SAY..	
		[inch]	[mm]	[mm]	[mm]	[mm]	[mm]	[mm]	[mm]	[mm]	[mm]	[kg]
VPI46.15L0.2	15	½	27	75	15,2	38	67,3	82,4	170	160	-	0,392
VPI46.15L0.6		½										
VPI46.20F1.4	20	¾	32	79	17,9	38	67,5	82,5	170	160	-	0,433
VPI46.25F1.8	25	1	39	83	22		70	85				0,548
VPI46.32F4	32	1-1/4	46	104	26	63	85	100	185	175	-	1,234
VPI46.15L0.2Q	15	½	27	75	60.2	38	67,3	82,4	170	160	-	0,504
VPI46.15L0.6Q		½			60.2							67,3
VPI46.20F1.4Q	20	¾	32	79	62.9	38	67,5	82,5	170	160	-	0,533
VPI46.25F1.8Q	25	1	39	83	59							70
VPI46.32F4Q	32	1-1/4	46	104	68	63	85	100	185	175	-	1,343
VPI46.40F9.5Q	40	1-1/2	56	138	71	90	161	-	-	-	500	3,28
VPI46.50F12Q	50	2	70	138	77		161	-				3,71

¹⁾ Total height including actuator

Revision Numbers

Product number	Valid from rev. no.	Product number	Valid from rev. no.
VPP46.10L0.2	..A	VPP46.10L0.2Q	..A
VPP46.15L0.2	..A	VPP46.15L0.2Q	..A
VPP46.15L0.6	..A	VPP46.15L0.6Q	..A
VPP46.20F1.4	..A	VPP46.20F1.4Q	..A
VPP46.25F1.8	..A	VPP46.25F1.8Q	..A
VPP46.32F4	..A	VPP46.32F4Q	..A
VPI46.15L0.2	..A	VPI46.15L0.2Q	..A
VPI46.15L0.6	..A	VPI46.15L0.6Q	..A
VPI46.20F1.4	..A	VPI46.20F1.4Q	..A
VPI46.25F1.8	..A	VPI46.25F1.8Q	..A
VPI46.32F4	..A	VPI46.32F4Q	..A
		VPI46.40F9.5Q	..A
		VPI46.50F12Q	..A

