

Rotary actuator fail-safe for adjusting dampers in technical building installations

- Air damper size up to approx. 0.8 m<sup>2</sup>
- Torque motor 4 Nm
- Nominal voltage AC 230 V
- Control Open/close
- with integrated auxiliary switch

**Technical data**

<b>Electrical data</b>	Nominal voltage	AC 230 V
	Nominal voltage frequency	50/60 Hz
	Nominal voltage range	AC 198...264 V
	Power consumption in operation	5 W
	Power consumption in rest position	3 W
	Power consumption for wire sizing	7 VA
	Power consumption for wire sizing note	I <sub>max</sub> 150 mA @ 10 ms
	Auxiliary switch	1 x SPDT, 0...100%
	Switching capacity auxiliary switch	1 mA...3 A (0.5 A inductive), AC 250 V
	Connection supply / control	Cable 1 m, 2 x 0.75 mm <sup>2</sup>
	Connection auxiliary switch	Cable 1 m, 3 x 0.75 mm <sup>2</sup>
	Parallel operation	Yes (note the performance data)
	<b>Functional data</b>	Torque motor
Torque fail-safe		4 Nm
Direction of motion motor		selectable by mounting L/R
Direction of motion fail-safe		selectable by mounting L/R
Manual override		No
Angle of rotation		Max. 95°
Angle of rotation note		Adjustable 37...100% with integrated mechanical limitation
Running time motor		40...75 s / 90°
Running time fail-safe		<20 s / 90° <20 s @ -20...50°C / <60 s @ -30°C
Sound power level, motor		50 dB(A)
Mechanical interface		Universal shaft clamp 8...16 mm
Position indication		Mechanical
Service life	Min. 60'000 fail-safe positions	
<b>Safety data</b>	Protection class IEC/EN	II, reinforced insulation
	Protection class auxiliary switch IEC/EN	II, reinforced insulation
	Degree of protection IEC/EN	IP54
	EMC	CE according to 2014/30/EU
	Low voltage directive	CE according to 2014/35/EU
	Certification IEC/EN	IEC/EN 60730-1 and IEC/EN 60730-2-14
	Mode of operation	Type 1.B
	Rated impulse voltage supply / control	4 kV
	Rated impulse voltage auxiliary switch	4 kV
	Pollution degree	3
	Ambient temperature	-30...50°C
	Storage temperature	-40...80°C

<b>Safety data</b>	Ambient humidity	Max. 95% RH, non-condensing
	Servicing	maintenance-free
<b>Weight</b>	Weight	1.7 kg

**Safety notes**

- The device must not be used outside the specified field of application, especially not in aircraft or in any other airborne means of transport.
- Outdoor application: only possible in case that no (sea) water, snow, ice, insulation or aggressive gases interfere directly with the device and that it is ensured that the ambient conditions remain within the thresholds according to the data sheet at any time.
- Caution: Power supply voltage!
- Only authorised specialists may carry out installation. All applicable legal or institutional installation regulations must be complied during installation.
- The device may only be opened at the manufacturer's site. It does not contain any parts that can be replaced or repaired by the user.
- Cables must not be removed from the device.
- To calculate the torque required, the specifications supplied by the damper manufacturers concerning the cross-section, the design, the installation situation and the ventilation conditions must be observed.
- The device contains electrical and electronic components and must not be disposed of as household refuse. All locally valid regulations and requirements must be observed.

**Product features**

<b>Mode of operation</b>	The actuator moves the damper to the operating position at the same time as tensioning the return spring. The damper is turned back to the safety position by spring energy when the supply voltage is interrupted.
<b>Simple direct mounting</b>	Simple direct mounting on the damper shaft with a universal shaft clamp, supplied with an anti-rotation device to prevent the actuator from rotating.
<b>Adjustable angle of rotation</b>	Adjustable angle of rotation with mechanical end stops.
<b>High functional reliability</b>	The actuator is overload protected, requires no limit switches and automatically stops when the end stop is reached.
<b>Flexible signalling</b>	With adjustable auxiliary switch (0...100%)

**Accessories**

Electrical accessories	Description	Type
	Feedback potentiometer 1 kΩ	P1000A-F
	Feedback potentiometer 200 Ω	P200A-F
	Auxiliary switch 2 x SPDT	S2A-F
Mechanical accessories	Description	Type
	Shaft extension 170 mm Ø10 mm for damper shaft Ø 6...16 mm	AV6-20
	Shaft clamp reversible, clamping range Ø16...20 mm	K6-1
	Ball joint suitable for damper crank arm KH8 / KH10	KG10A
	Ball joint suitable for damper crank arm KH8	KG8
	Actuator arm, clamping range Ø8...16 mm, Slot width 8.2 mm	KH-LF
	Damper crank arm Slot width 8.2 mm, clamping range Ø10...18 mm	KH8
	Anti-rotation mechanism 180 mm, Multipack 20 pcs.	Z-ARS180L
	Angle of rotation limiter, with end stop	ZDB-LF
	Form fit adapter 8x8 mm	ZF8-LF
	Mounting kit for linkage operation for flat installation	ZG-LF1
	Mounting kit for linkage operation for side installation Slot width 6.2 mm	ZG-LF3

Electrical installation



**Caution: Power supply voltage!**  
Parallel connection of other actuators possible. Observe the performance data.

**Wiring diagrams**

AC 230 V, open/close

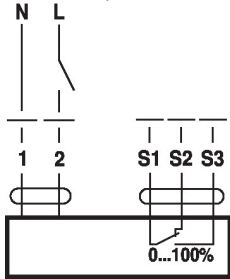

Cable colours:

- 1 = blue
- 2 = brown
- S1 = white
- S2 = white
- S3 = white

Dimensions

Dimensional drawings

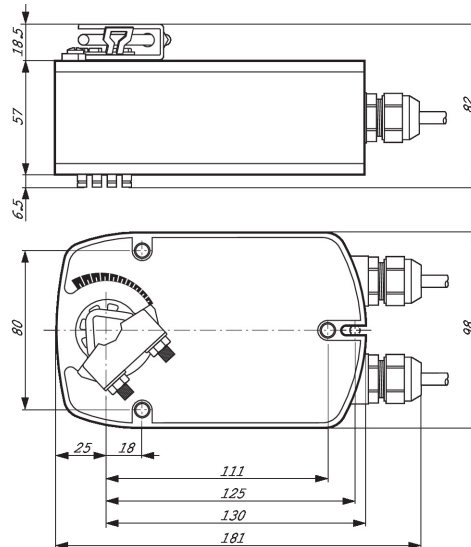

Clamping range

8...16	8...16

Shaft length

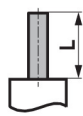

Min. 84

Min. 20